

STEREO 2.8-W AUDIO POWER AMPLIFIER WITH DC VOLUME CONTROL AND MUX CONTROL

FEATURES

- Compatible With PC 99 Desktop Line-Out Into 10-k Ω Load
- Compatible With PC 99 Portable Into 8- Ω Load
- Internal Gain Control, Which Eliminates External Gain-Setting Resistors
- DC Volume Control From 20 dB to -40 dB
- 2.8-W/Ch Output Power Into 3- Ω Load
- Input MUX Select Terminal
- PC-Beep Input
- Depop Circuitry
- Stereo Input MUX
- Fully Differential Input
- Low Supply Current and Shutdown Current
- Surface-Mount Power Packaging 24-Pin TSSOP PowerPAD™

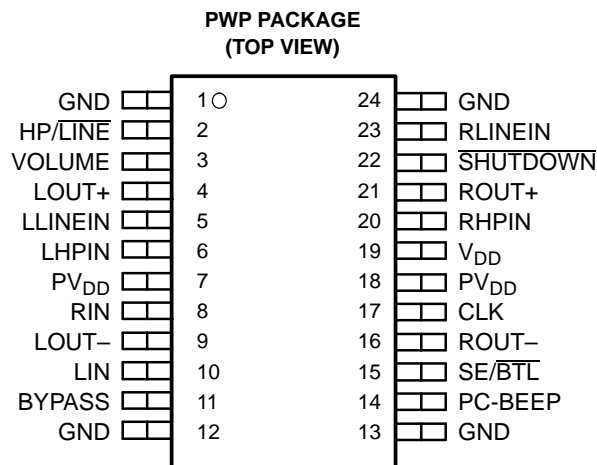

DESCRIPTION

The TPA0242 is a stereo audio power amplifier in a 24-pin TSSOP thermally-enhanced package capable of delivering 2.8 W of continuous RMS power per channel into 3- Ω loads.

This device minimizes the number of external components needed, which simplifies the design and frees up board space for other features. When driving 1 W into 8- Ω speakers, the TPA0242 has less than 0.22% THD+N across its specified frequency range.

The integrated depop circuitry virtually eliminates transients that cause noise in the speakers.

Amplifier gain is controlled by a dc voltage input on the VOLUME terminal. There are 31 discrete steps covering the range of 20 dB (maximum volume setting) to -40 dB (minimum volume setting) in 2 dB steps. When the VOLUME terminal exceeds 3.54 V, the device is muted. An internal input MUX allows two sets of stereo inputs to the amplifier. The HP/LINE terminal allows the user to select which MUX input is active regardless of whether the amplifier is in single-ended (SE) or bridge-tied load (BTL) mode. In notebook applications, where internal speakers are driven as BTL and the line outputs (often headphone drive) are required to be SE, the TPA0242 automatically switches into SE mode when the SE/BTL input is activated, and this effectively reduces the gain by 6 dB.

The TPA0242 consumes only 20 mA of supply current during normal operation. A miserly shutdown mode reduces the supply current to 150 μ A.

The PowerPAD package (PWP) delivers a level of thermal performance that was previously achievable only in TO-220-type packages. Thermal impedances of approximately 35°C/W are truly realized in multilayer PCB applications. This allows the TPA0242 to operate at full power into 8- Ω loads at ambient temperatures of 85°C.



Please be aware that an important notice concerning availability, standard warranty, and use in critical applications of Texas Instruments semiconductor products and disclaimers thereto appears at the end of this data sheet.

PowerPAD is a trademark of Texas Instruments.



These devices have limited built-in ESD protection. The leads should be shorted together or the device placed in conductive foam during storage or handling to prevent electrostatic damage to the MOS gates.

ORDERING INFORMATION

T _A	PACKAGED DEVICE
	TSSOP ⁽¹⁾ (PWP)
-40°C to 85°C	TPA0242PWP

(1) The PWP package is available taped and reeled. To order a taped and reeled part, add the suffix R to the part number (e.g., TPA0242PWPR).

FUNCTIONAL BLOCK DIAGRAM

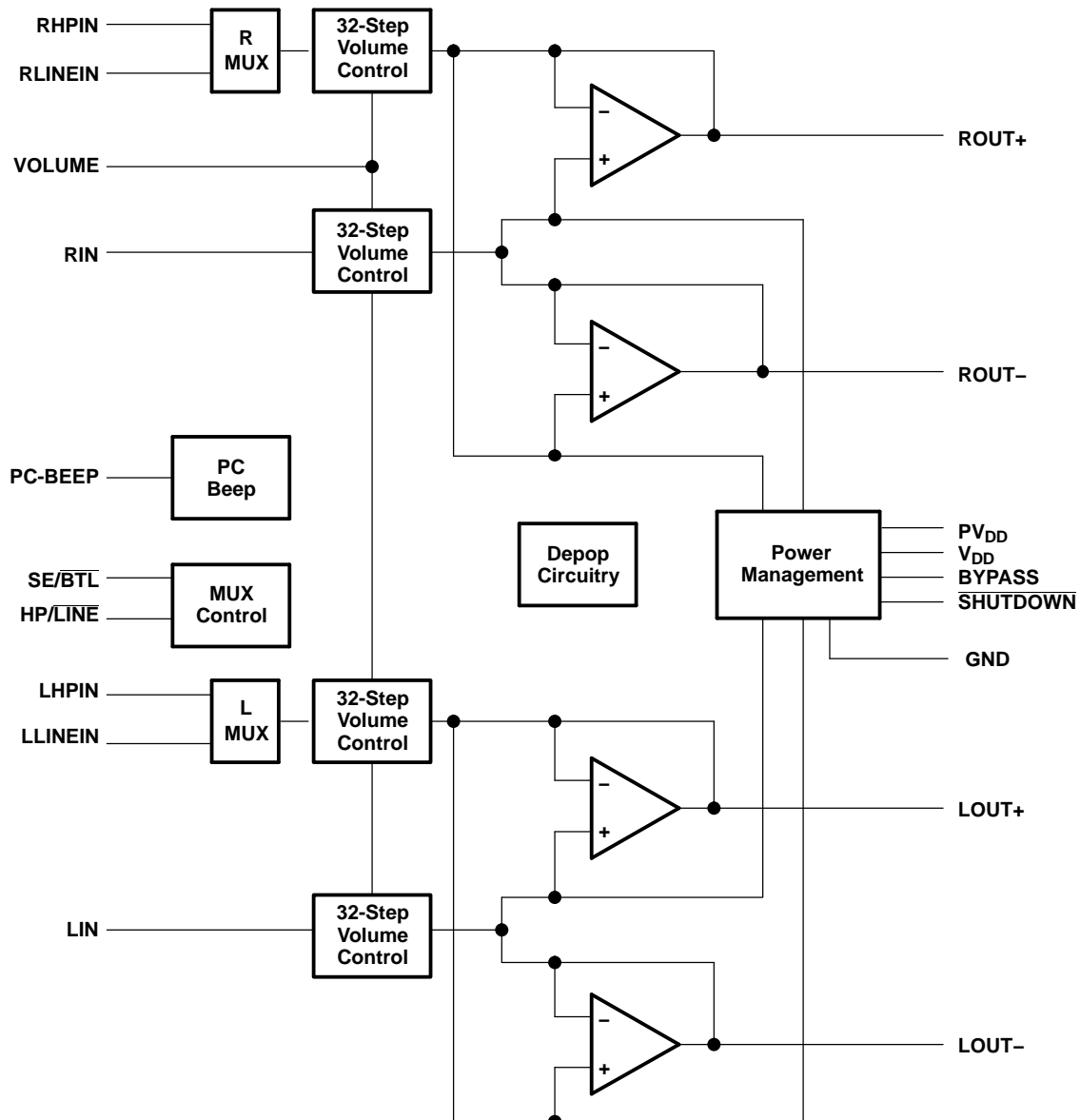

Terminal Functions

TERMINAL NAME	NO.	I/O	DESCRIPTION
BYPASS	11		Tap to voltage divider for internal mid-supply bias generator
CLK	17	I	If a 47-nF capacitor is attached, the TPA0242 generates an internal clock. An external clock can override the internal clock input to this terminal.
GND	1, 12 13, 24		Ground connection for circuitry. Connected to thermal pad
LHPIN	6	I	Left channel headphone input, selected when SE/ $\overline{\text{BTL}}$ is held high
LIN	10	I	Common left input for fully differential input. AC ground for single-ended inputs
LLINEIN	5	I	Left channel line negative input, selected when SE/ $\overline{\text{BTL}}$ is held low
LOUT+	4	O	Left channel positive output in $\overline{\text{BTL}}$ mode and positive output in SE mode
LOUT-	9	O	Left channel negative output in $\overline{\text{BTL}}$ mode and high-impedance in SE mode
HP/ $\overline{\text{LINE}}$	2	I	HP/ $\overline{\text{LINE}}$ is the input MUX control input. When the HP/ $\overline{\text{LINE}}$ terminal is held high, the headphone inputs (LHPIN or RHPIN [6, 20]) are active. When the HP/ $\overline{\text{LINE}}$ terminal is held low, the line BTL inputs (LLINEIN or RLINEIN [5, 23]) are active.
PC-BEEP	14	I	The input for PC-beep mode. PC-BEEP is enabled when a > 1.5-V _{PP} (peak-to-peak) square wave is input to PC-BEEP.
PV _{DD}	7, 18	I	Power supply for output stage
RHPIN	20	I	Right channel headphone input, selected when SE/ $\overline{\text{BTL}}$ is held high
RIN	8	I	Common right input for fully differential input. AC ground for single-ended inputs
RLINEIN	23	I	Right channel line input, selected when SE/ $\overline{\text{BTL}}$ is held low
ROUT+	21	O	Right channel positive output in $\overline{\text{BTL}}$ mode and positive output in SE mode
ROUT-	16	O	Right channel negative output in $\overline{\text{BTL}}$ mode and high-impedance in SE mode
SE/ $\overline{\text{BTL}}$	15	I	Hold SE/ $\overline{\text{BTL}}$ low for BTL mode and hold high for SE mode.
$\overline{\text{SHUTDOWN}}$	22	I	When held low, this terminal places the entire device, except PC-BEEP detect circuitry, in shutdown mode.
V _{DD}	19	I	Analog V _{DD} input supply. This terminal needs to be isolated from PV _{DD} to achieve highest performance.
VOLUME	3	I	VOLUME detects the dc level at the terminal and sets the gain for 31 discrete steps covering a range of 20 dB to -40 dB for dc levels of 0.15 V to 3.54. When the dc level is over 3.54 V, the device is muted.
Thermal Pad			Connect to ground. Must be soldered down in all applications to properly secure device on PC board.

ABSOLUTE MAXIMUM RATINGS

over operating free-air temperature range (unless otherwise noted) ⁽¹⁾

	UNIT
Supply voltage, V _{DD}	6 V
Input voltage, V _I	-0.3 V to V _{DD} 0.3 V
Continuous total power dissipation	Internally Limited (see Dissipation Rating Table)
Operating free-air temperature range, T _A	-40°C to 85°C
Operating junction temperature range, T _J	-40°C to 150°C
Storage temperature range, T _{stg}	-65°C to 85°C
Lead temperature 1,6 mm (1/16 inch) from case for 10 seconds	260°C

- (1) Stresses beyond those listed under "absolute maximum ratings" may cause permanent damage to the device. These are stress ratings only, and functional operation of the device at these or any other conditions beyond those indicated under "recommended operating conditions" is not implied. Exposure to absolute-maximum-rated conditions for extended periods may affect device reliability.

DISSIPATION RATING TABLE

PACKAGE	$T_A \leq 25^\circ\text{C}$	DERATING FACTOR	$T_A = 70^\circ\text{C}$	$T_A = 85^\circ\text{C}$
PWP	2.7 W ⁽¹⁾	21.8 mW/°C	1.7 W	1.4 W

- (1) Please see the Texas Instruments document, *PowerPAD Thermally Enhanced Package Application Report* (literature number SLMA002), for more information on the PowerPAD package. The thermal data was measured on a PCB layout based on the information in the section entitled *Texas Instruments Recommended Board for PowerPAD* on page 33 of the before mentioned document.

RECOMMENDED OPERATING CONDITIONS

		MIN	MAX	UNIT
Supply voltage, V_{DD}		4.5	5.5	V
High-level input voltage, V_{IH}	SE/BTL, HP/LINE	$0.8 \times V_{DD}$		V
	SHUTDOWN	2		
Low-level input voltage, V_{IL}	SE/BTL, HP/LINE	$0.6 \times V_{DD}$		V
	SHUTDOWN	0.8		
Operating free-air temperature, T_A		-40	85	°C

ELECTRICAL CHARACTERISTICS

at specified free-air temperature, $V_{DD} = 5\text{ V}$, $T_A = 25^\circ\text{C}$ (unless otherwise noted)

PARAMETER		TEST CONDITIONS	MIN	TYP	MAX	UNIT
$ V_{OS} $	Output offset voltage (measured differentially)	$V_I = 0$, $A_v = 2\text{ V/V}$			35	mV
	Supply ripple rejection ratio	$V_{DD} = 4.9\text{ V to } 5.1\text{ V}$		67		dB
$ I_{IH} $	High-level input current - SHUTDOWN, SE/BTL, HP/LINE, VOLUME	$V_{DD} = 5.5\text{ V}$, $V_I = V_{DD}$			900	nA
$ I_{IL} $	Low-level input current - SHUTDOWN, SE/BTL, HP/LINE, VOLUME	$V_{DD} = 5.5\text{ V}$, $V_I = 0\text{ V}$			900	nA
I_{DD}	Supply current	BTL mode, SHUTDOWN = 2 V, SE/BTL, HP/LINE = $0.6 \times V_{DD}$		20	25	mA
		SE mode, SHUTDOWN = 2 V, SE/BTL, HP/LINE = $0.8 \times V_{DD}$		10	12.5	
$I_{DD(SD)}$	Supply current, shutdown mode	SHUTDOWN = 0 V, SE/BTL, HP/LINE = 0 V		150	300	μA

OPERATING CHARACTERISTICS

$V_{DD} = 5\text{ V}$, $T_A = 25^\circ\text{C}$, $R_L = 4\Omega$, Gain = 2 V/V, BTL mode (unless otherwise noted)

PARAMETER		TEST CONDITIONS		MIN	TYP	MAX	UNIT
P_O	Output power	$R_L = 3\Omega$, $f = 1\text{ kHz}$	THD = 10%		2.8		W
			THD = 1%		2.2		
THD+N	Total harmonic distortion plus noise	$P_O = 1\text{ W}$, $f = 20\text{ Hz to } 15\text{ kHz}$			0.22%		
B_{OM}	Maximum output power bandwidth	THD = 5%			>15		kHz
	Supply ripple rejection ratio	$f = 1\text{ kHz}$, $C_{(BYP)} = 0.47\text{ }\mu\text{F}$	BTL mode		-65		dB
			SE mode		-60		
V_n	Noise output voltage	$C_{(BYP)} = 0.47\text{ }\mu\text{F}$, $f = 20\text{ Hz to } 20\text{ kHz}$	BTL mode		34		μV_{RMS}
			SE mode		44		

TYPICAL CHARACTERISTICS

Table of Graphs

		FIGURE		
THD+N	Total harmonic distortion plus noise	vs Output power	1, 4, 6, 8, 10	
		vs Voltage gain	2	
		vs Frequency	3, 5, 7, 9, 11	
		vs Output voltage	12	
V_n	Output noise voltage	vs Bandwidth	13	
		Supply ripple rejection ratio	vs Frequency	14, 15
		Crosstalk	vs Frequency	16, 17, 18
		Shutdown attenuation	vs Frequency	19
SNR	Signal-to-noise ratio	vs Bandwidth	20	
		Closed loop response	21, 22	
P_O	Output power	vs Load resistance	23, 24	
P_D	Power dissipation	vs Output power	25, 26	
		vs Ambient temperature	27	
Z_I	Input impedance	vs Gain	28	

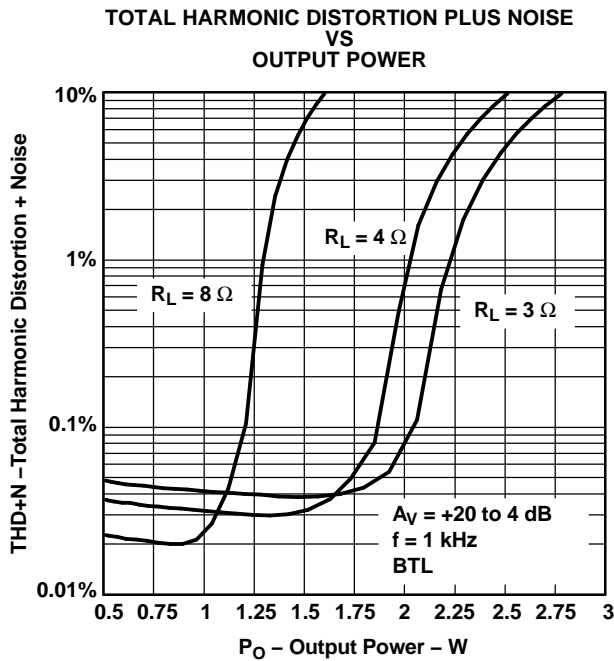

Figure 1.

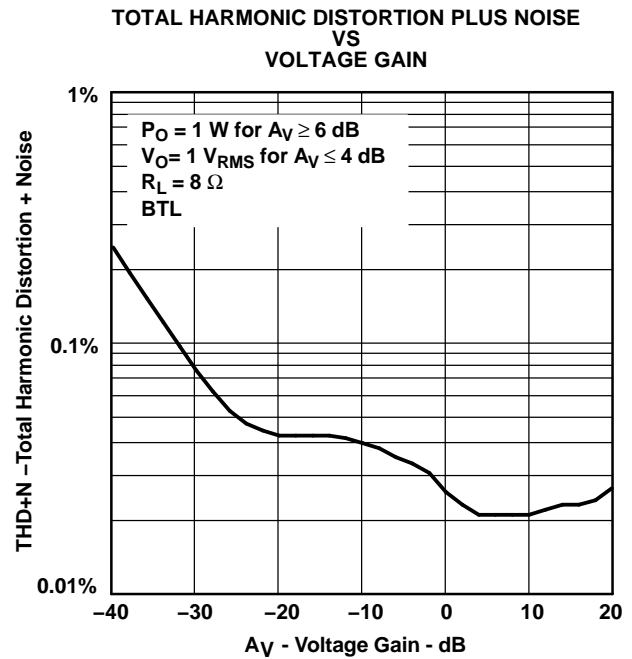

Figure 2.

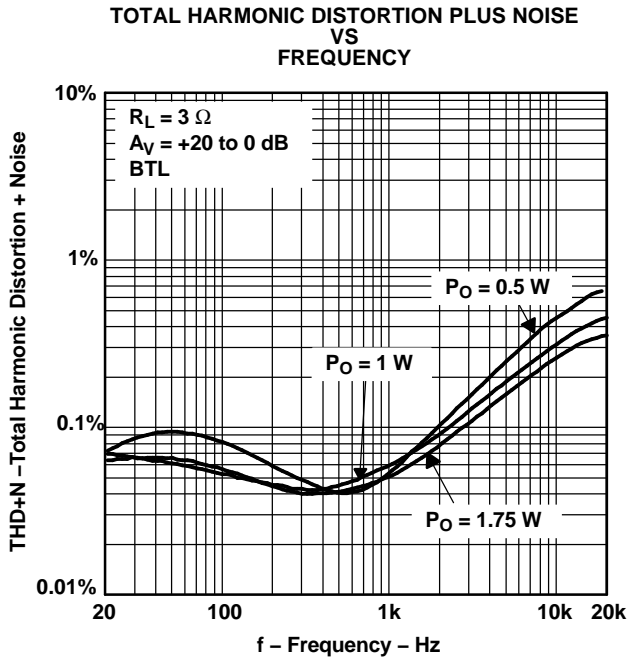

Figure 3.

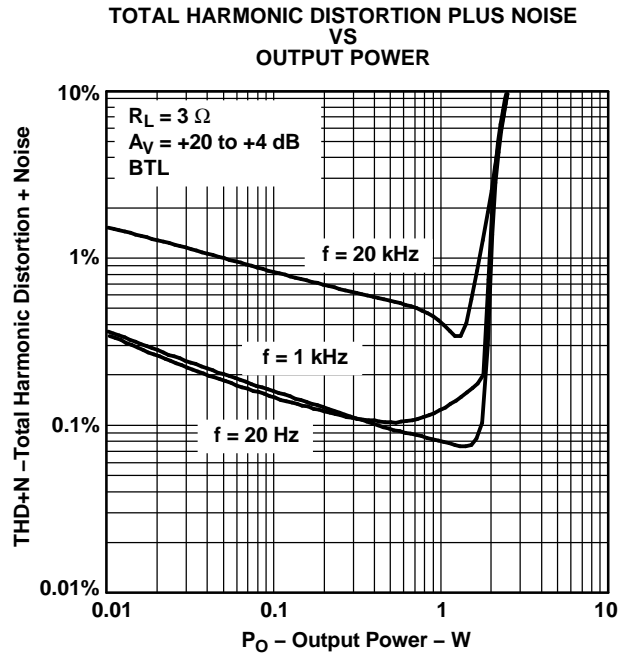

Figure 4.

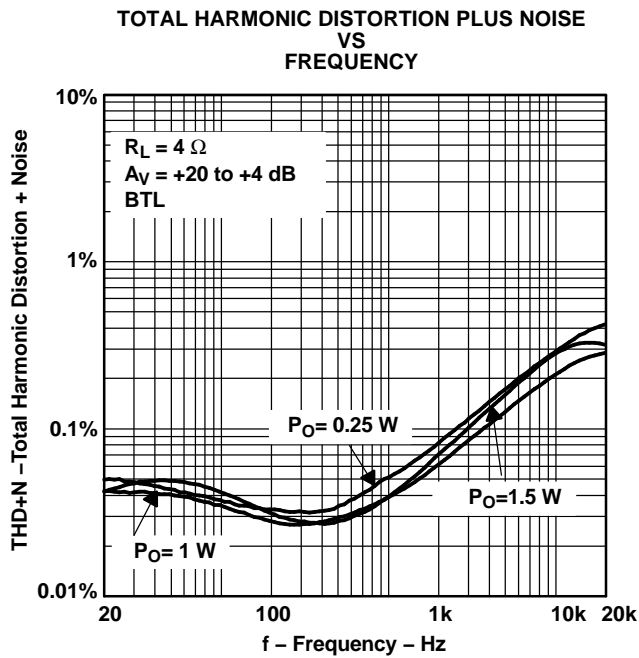

Figure 5.

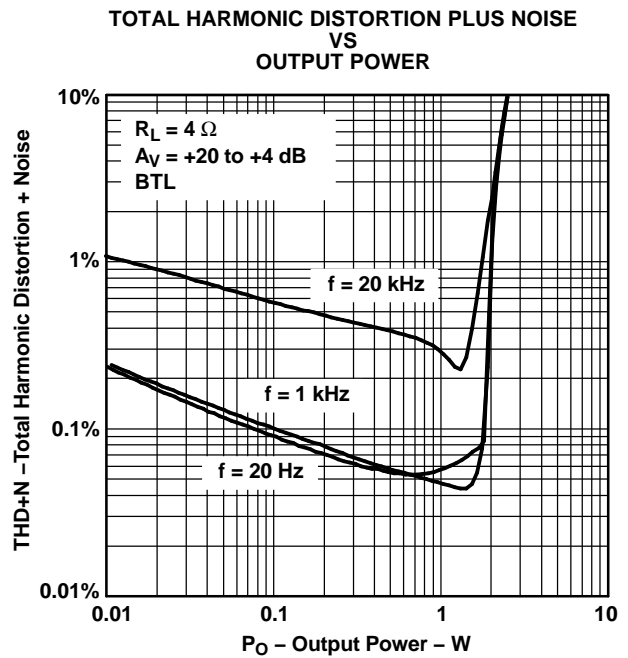

Figure 6.

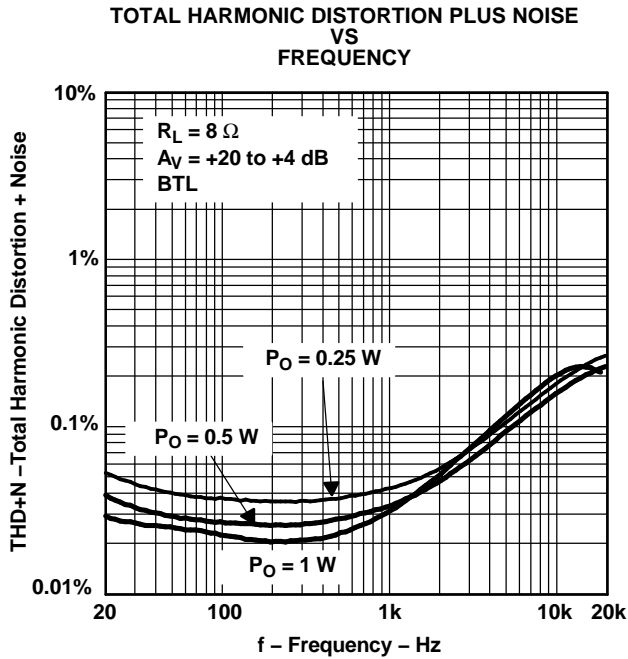

Figure 7.

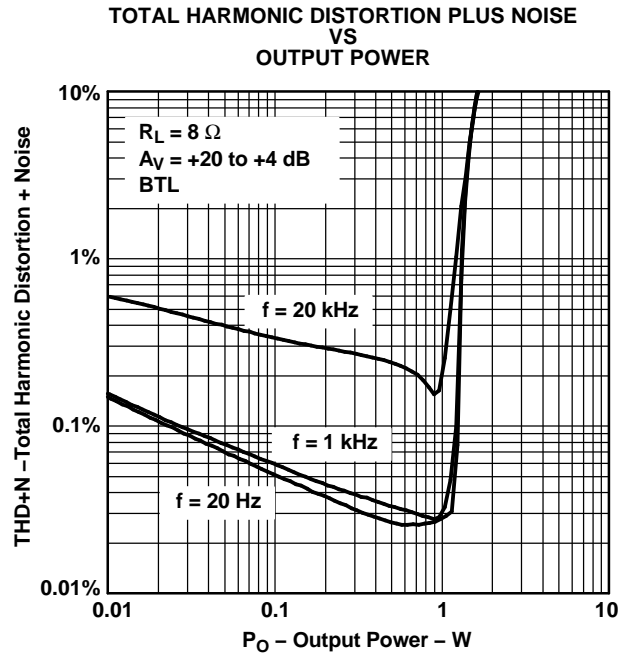

Figure 8.

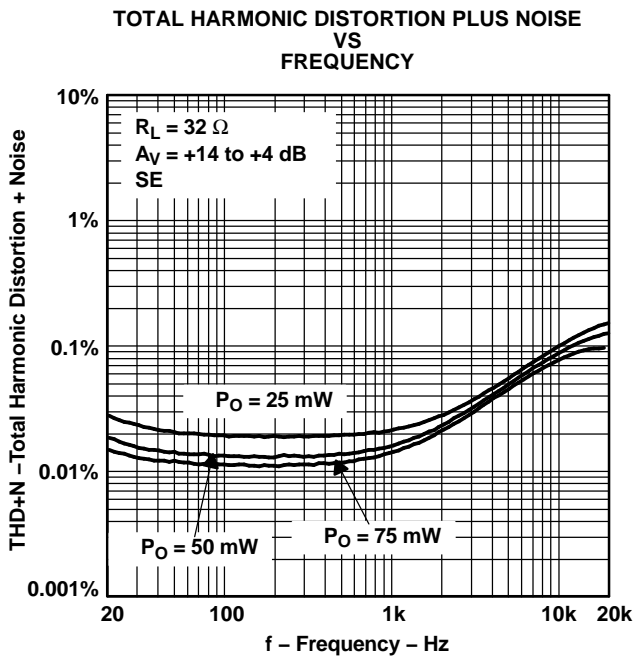

Figure 9.

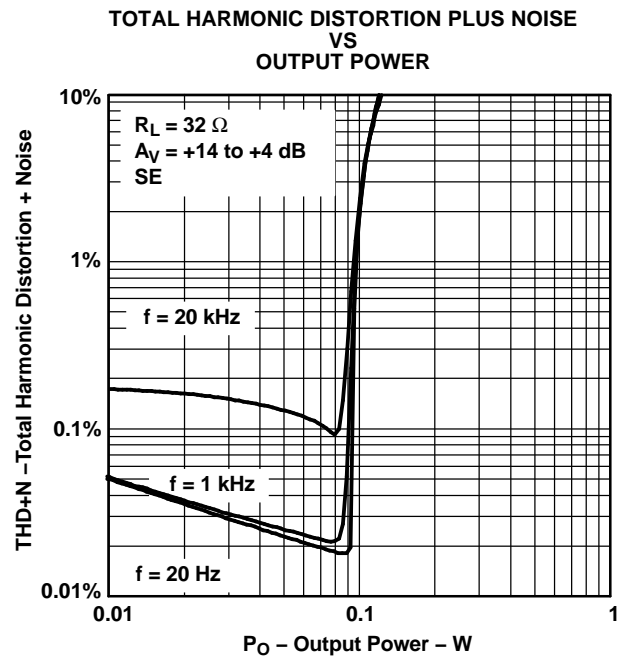

Figure 10.

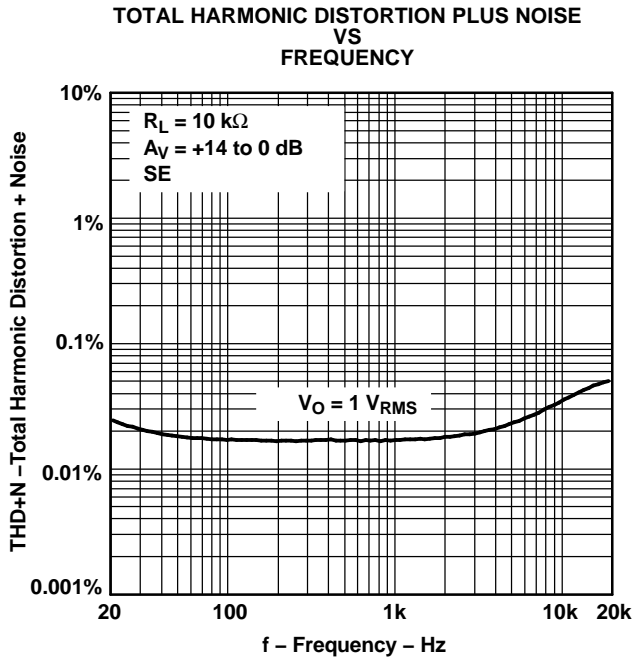

Figure 11.

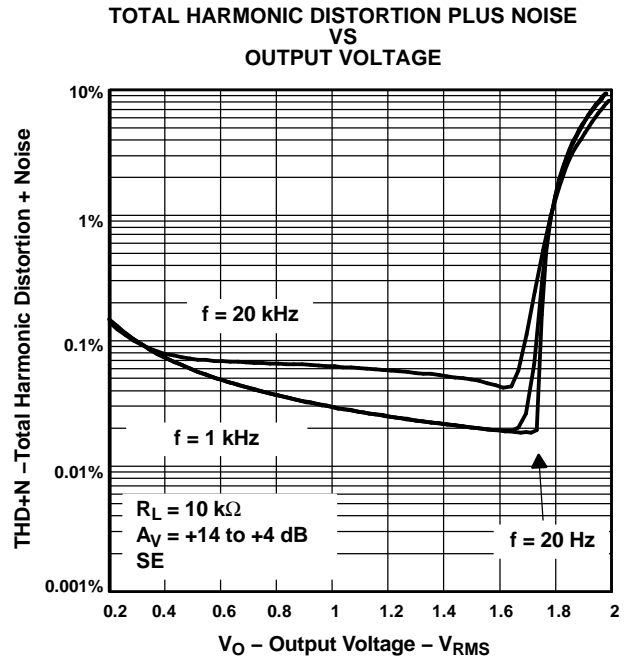

Figure 12.

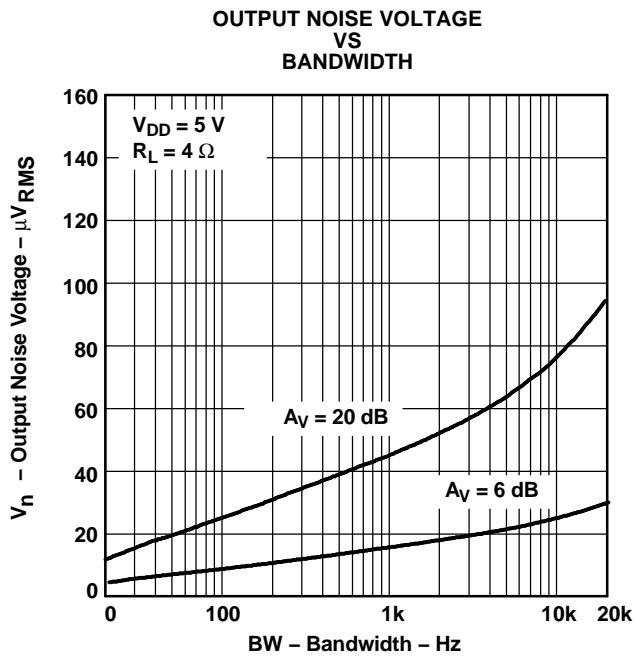

Figure 13.

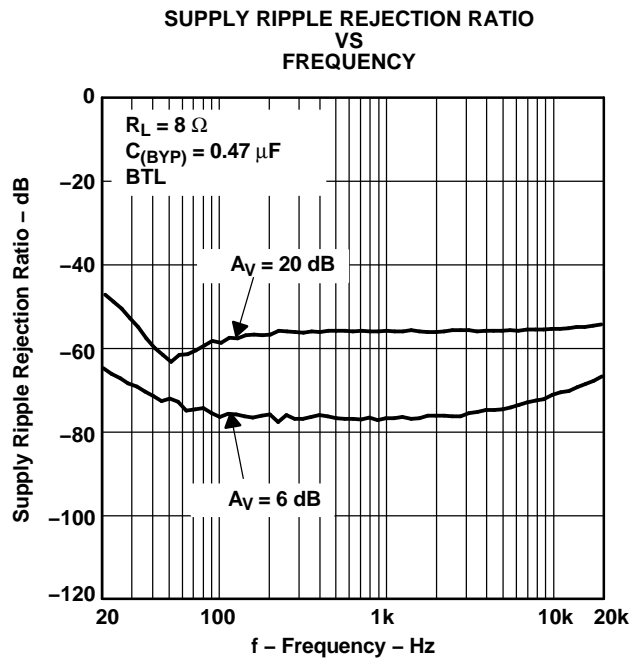

Figure 14.

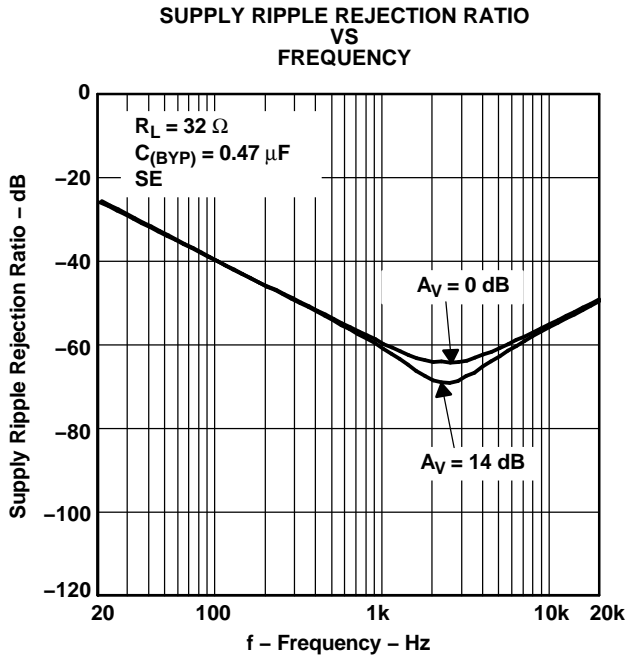

Figure 15.

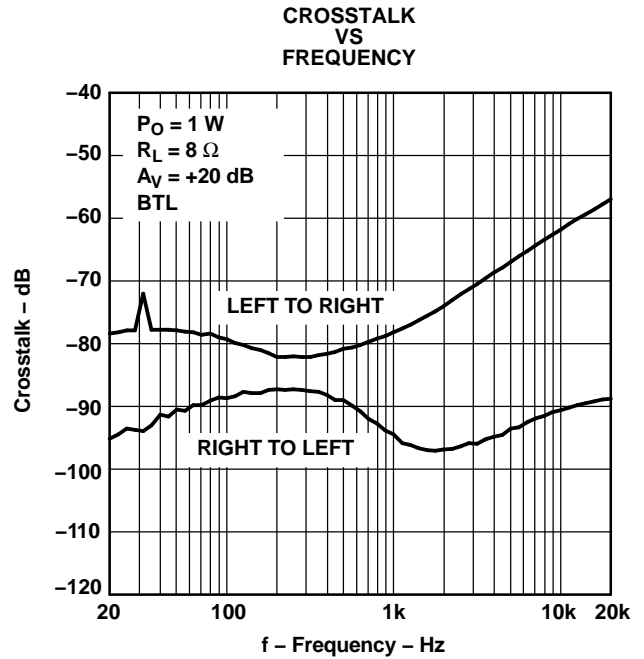

Figure 16.

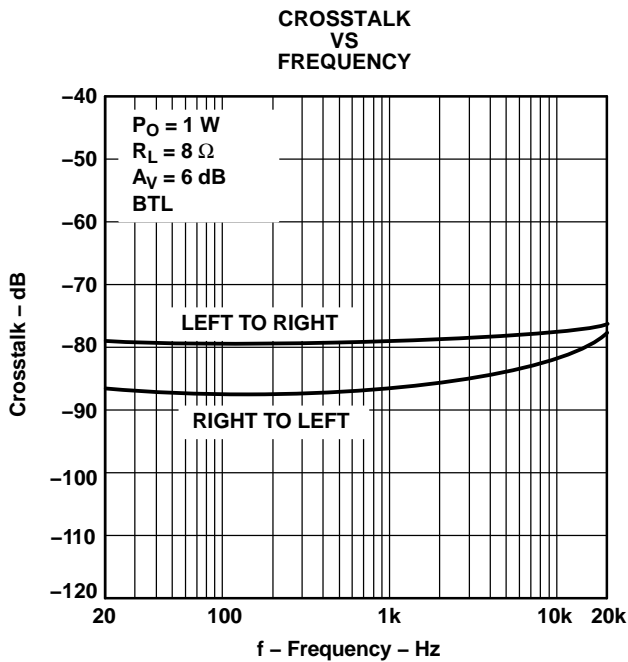

Figure 17.

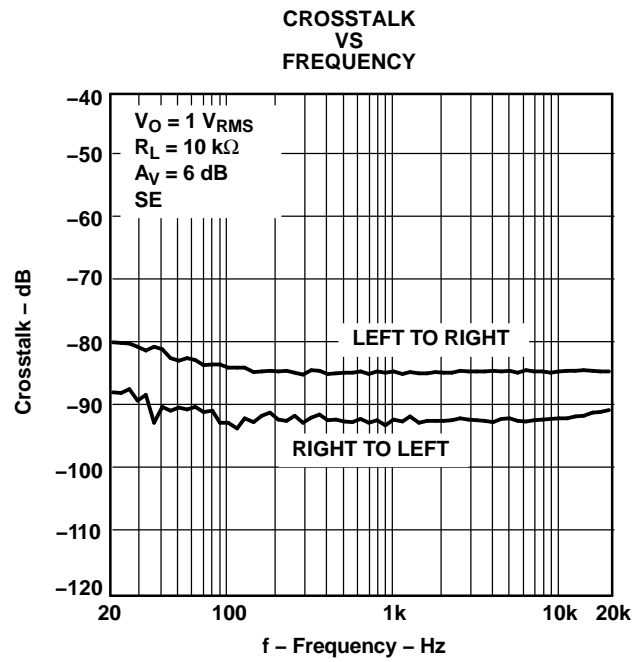

Figure 18.

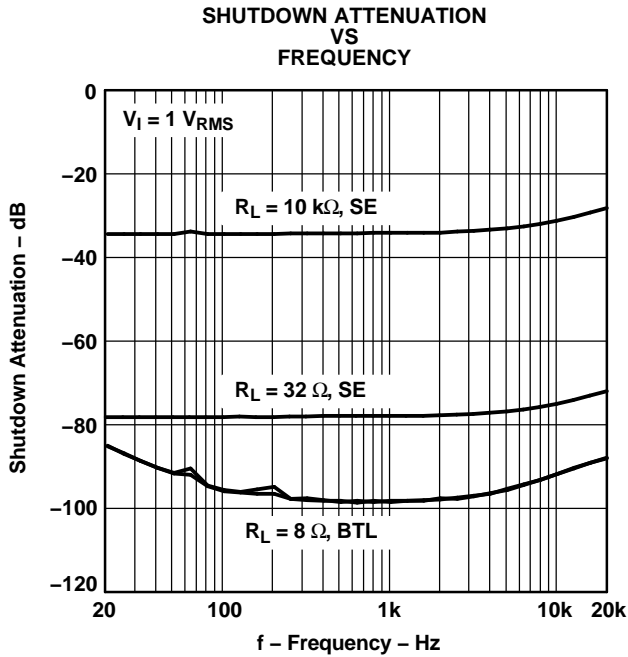

Figure 19.

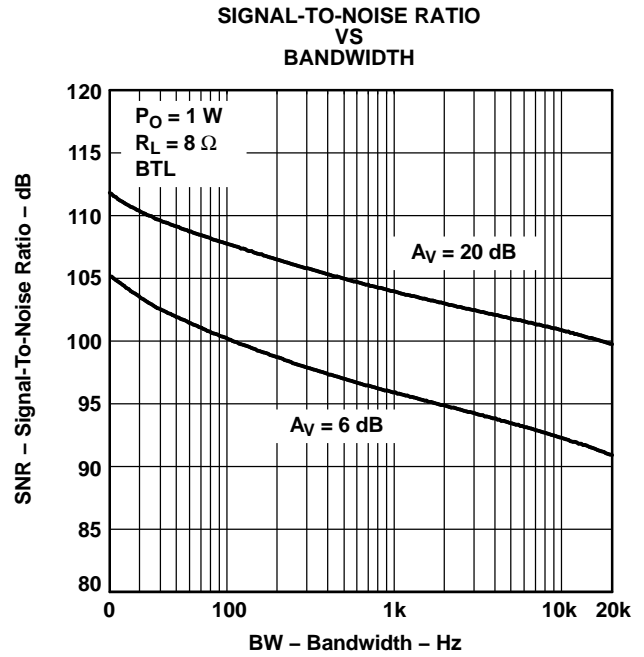

Figure 20.

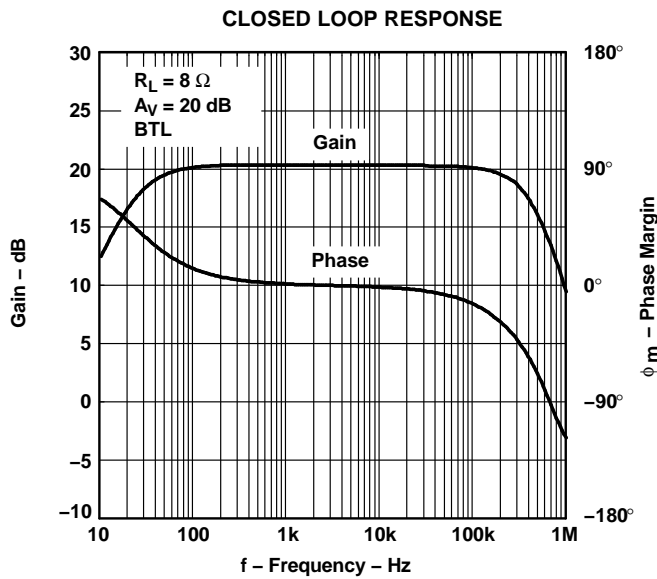

Figure 21.

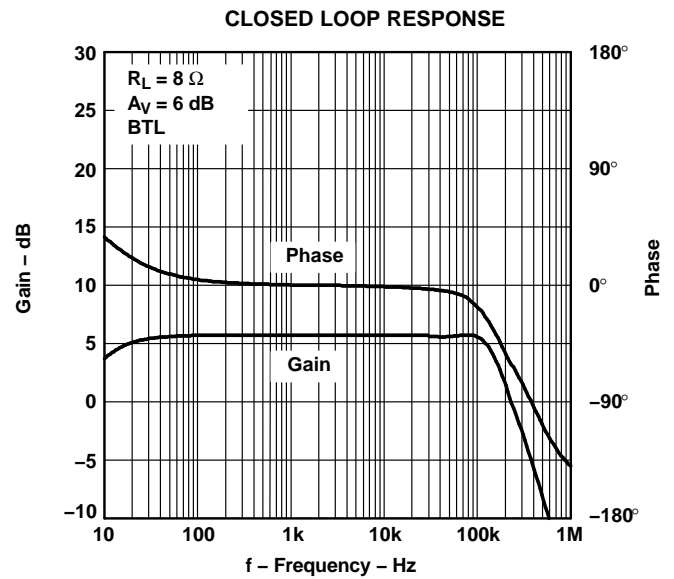

Figure 22.

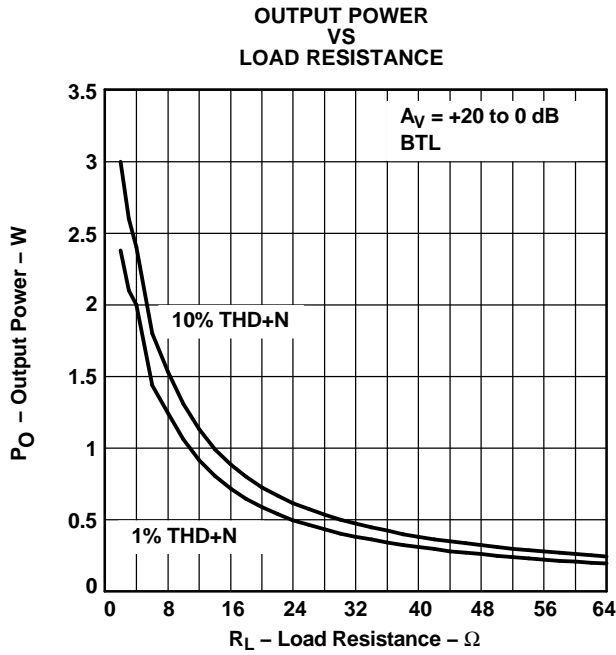

Figure 23.

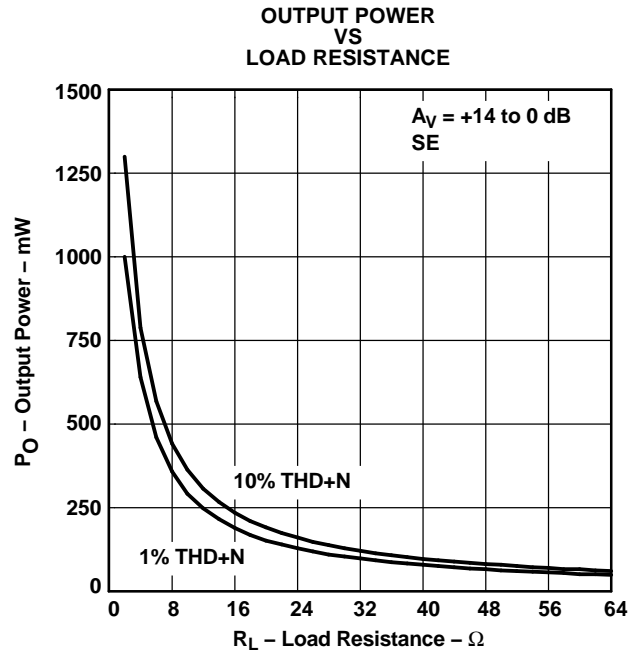

Figure 24.

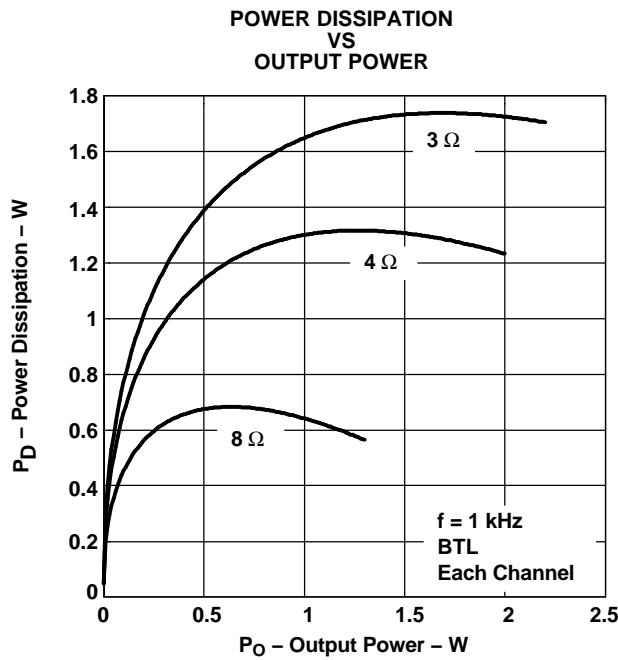

Figure 25.

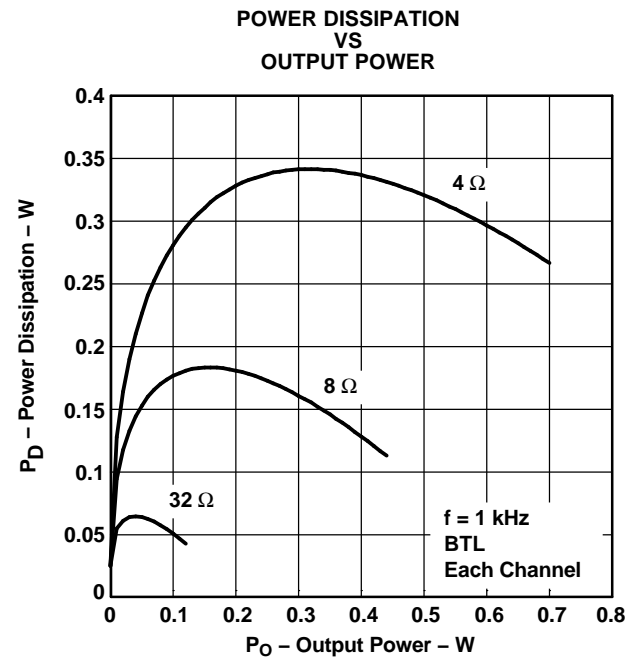

Figure 26.

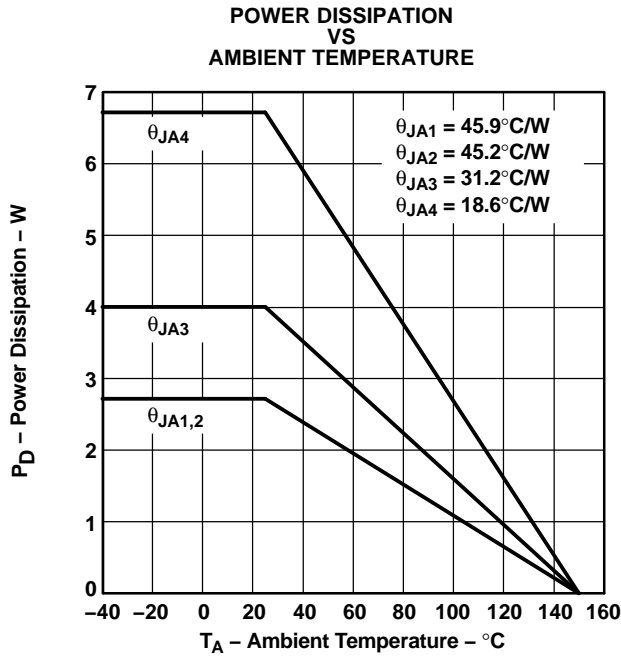

Figure 27.

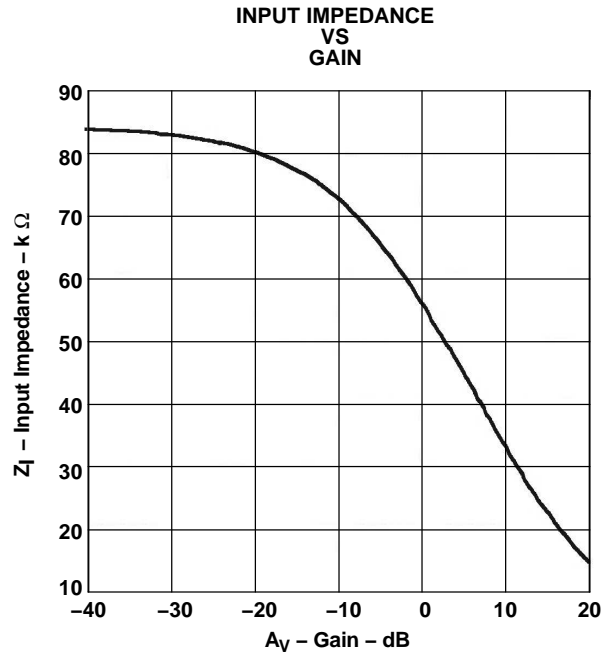

Figure 28.

Volume Control Characteristics

Table 1. Typical DC Volume Control⁽¹⁾

VOLUME (Terminal 3)		TYPICAL GAIN of AMPLIFIER (dB) ⁽²⁾
VOLTAGE INCREASING OR FIXED GAIN (V)	VOLTAGE DECREASING (V)	
0-0.27	0.16-0	20
0.28-0.37	0.28-0.17	18
0.38-0.48	0.39-0.29	16
0.49-0.58	0.50-0.40	14
0.59-0.69	0.61-0.51	12
0.70-0.80	0.72-0.62	10
0.81-0.91	0.84-0.73	8
0.92-1.02	0.95-0.85	6
1.03-1.13	1.06-0.96	4
1.14-1.24	1.17-1.07	2
1.25-1.35	1.29-1.18	0
1.36-1.46	1.40-1.30	-2
1.47-1.58	1.51-1.41	-4
1.59-1.68	1.62-1.52	-6
1.69-1.79	1.73-1.63	-8
1.80-1.90	1.84-1.74	-10
1.91-2.01	1.96-1.85	-12
2.02-2.12	2.06-1.97	-14
2.13-2.23	2.18-2.07	-16
2.24-2.34	2.29-2.19	-18
2.35-2.45	2.41-2.30	-20
2.46-2.56	2.52-2.42	-22
2.57-2.67	2.62-2.53	-24
2.68-2.78	2.74-2.63	-26
2.79-2.90	2.86-2.75	-28
2.91-3.01	2.97-2.87	-30
3.02-3.12	3.07-2.98	-32
3.13-3.23	3.19-3.08	-34
3.24-3.33	3.29-3.20	-36
3.34-3.44	3.40-3.30	-38
3.45-3.55	3.53-3.41	-40
3.56-5.00	5.00-3.54	-85

- (1) Each step is tested at its midpoint and characterized within ± 4 dB of the specified gain value for $V_{DD} = 5$ V. For $V_{DD} = 4.5$ V to 5.5 V, multiply values by 90% and 110%, respectively.
- (2) 95% of the characterized values lie within ± 0.5 dB of the specified gain value. Figure 29 shows the typical behavior of most devices.

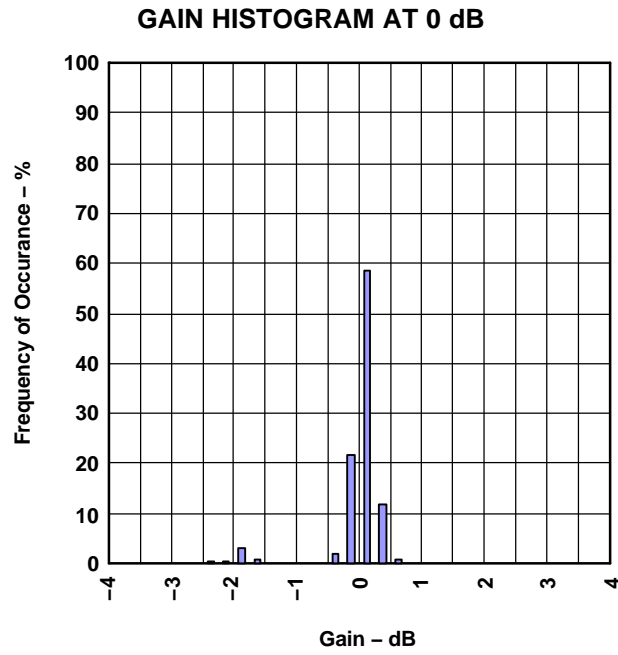

Figure 29. Typical Gain Variance

THERMAL INFORMATION

The thermally-enhanced PWP package is based on the 24-pin TSSOP, but includes a thermal pad (see Figure 30) to provide an effective thermal contact between the IC and the PWB.

Traditionally, surface mount and power have been mutually exclusive terms. A variety of scaled-down TO-220-type packages have leads formed as gull wings to make them applicable for surface-mount applications. However, These packages have two shortcomings: they do not address the very low-profile requirements (<2 mm) of many of today's advanced systems, and they do not offer a high-enough terminal count to accommodate increasing integration. On the other hand, traditional low-power surface-mount packages require power dissipation derating that severely limits the usable range of many high-performance analog circuits.

The PowerPAD package (thermally enhanced TSSOP) combines fine-pitch surface-mount technology with thermal performance comparable to much larger power packages.

The PowerPAD package is designed to optimize the heat transfer to the PWB. Because of the very small size and limited mass of a TSSOP package, thermal enhancement is achieved by improving the thermal conduction paths that remove heat from the component. The thermal pad is formed using a patented lead-frame design and manufacturing technique to provide a direct connection to the heat-generating IC. When this pad is soldered or otherwise thermally coupled to an external heat dissipator, high power dissipation in the ultrathin, fine-pitch, surface-mount package can be reliably achieved.

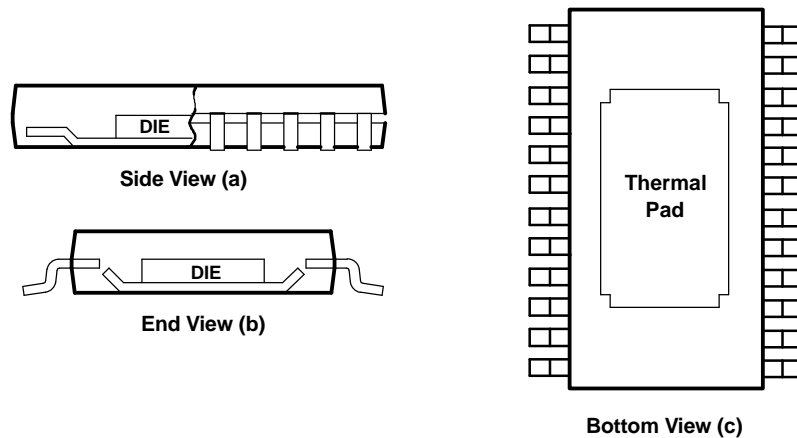
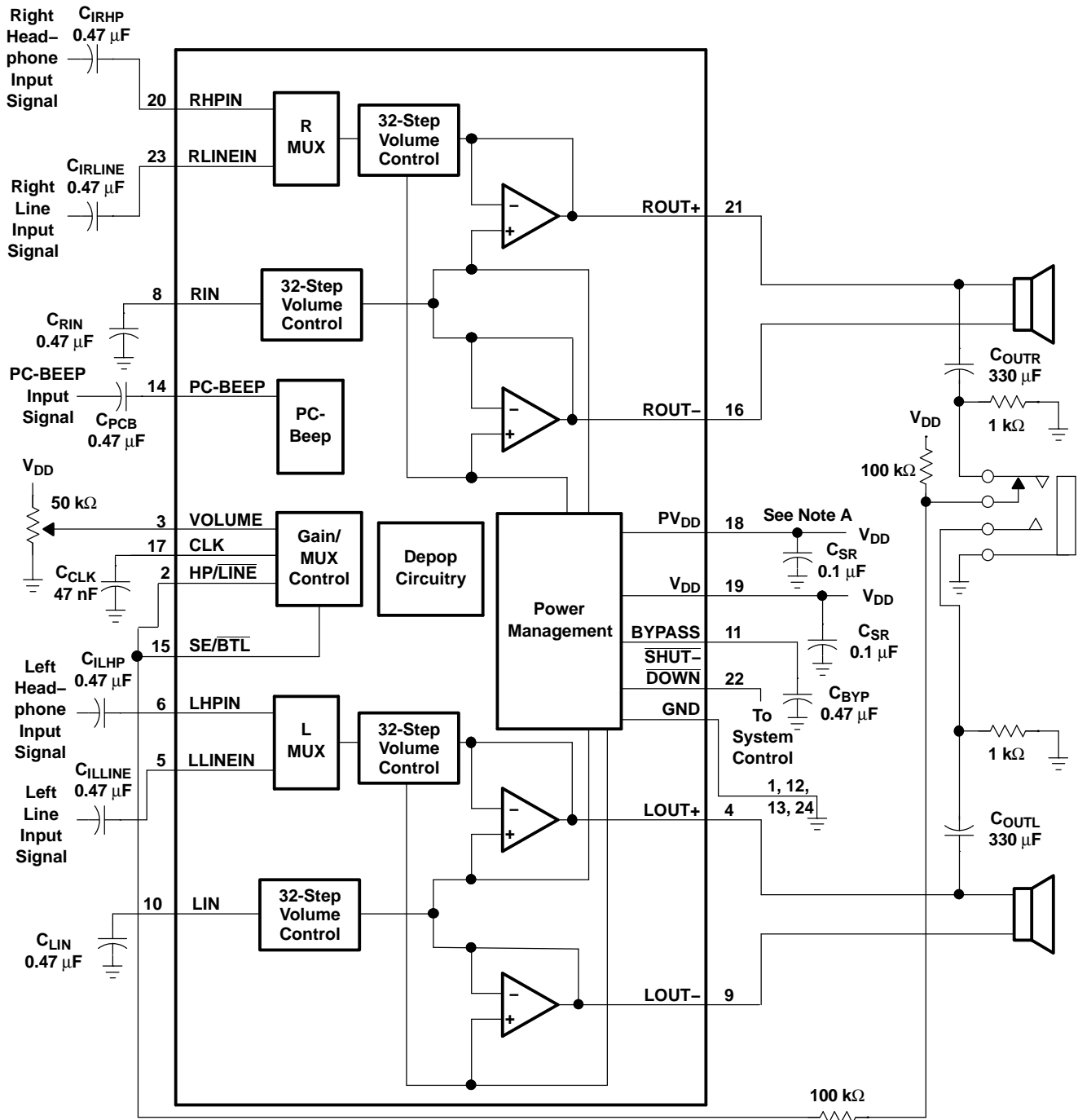

Figure 30. Views of Thermally Enhanced PWP Package

APPLICATION INFORMATION

Component Selection

Figure 31 and Figure 32 are schematic diagrams of typical notebook computer application circuits.



- A. A 0.1- μF ceramic capacitor should be placed as close as possible to the IC. For filtering lower-frequency noise signals, a larger electrolytic capacitor of 10 μF or greater should be placed near the audio power amplifier.

Figure 31. Typical TPA0242 Application Circuit Using Single-Ended Inputs and Input MUX

APPLICATION INFORMATION (continued)

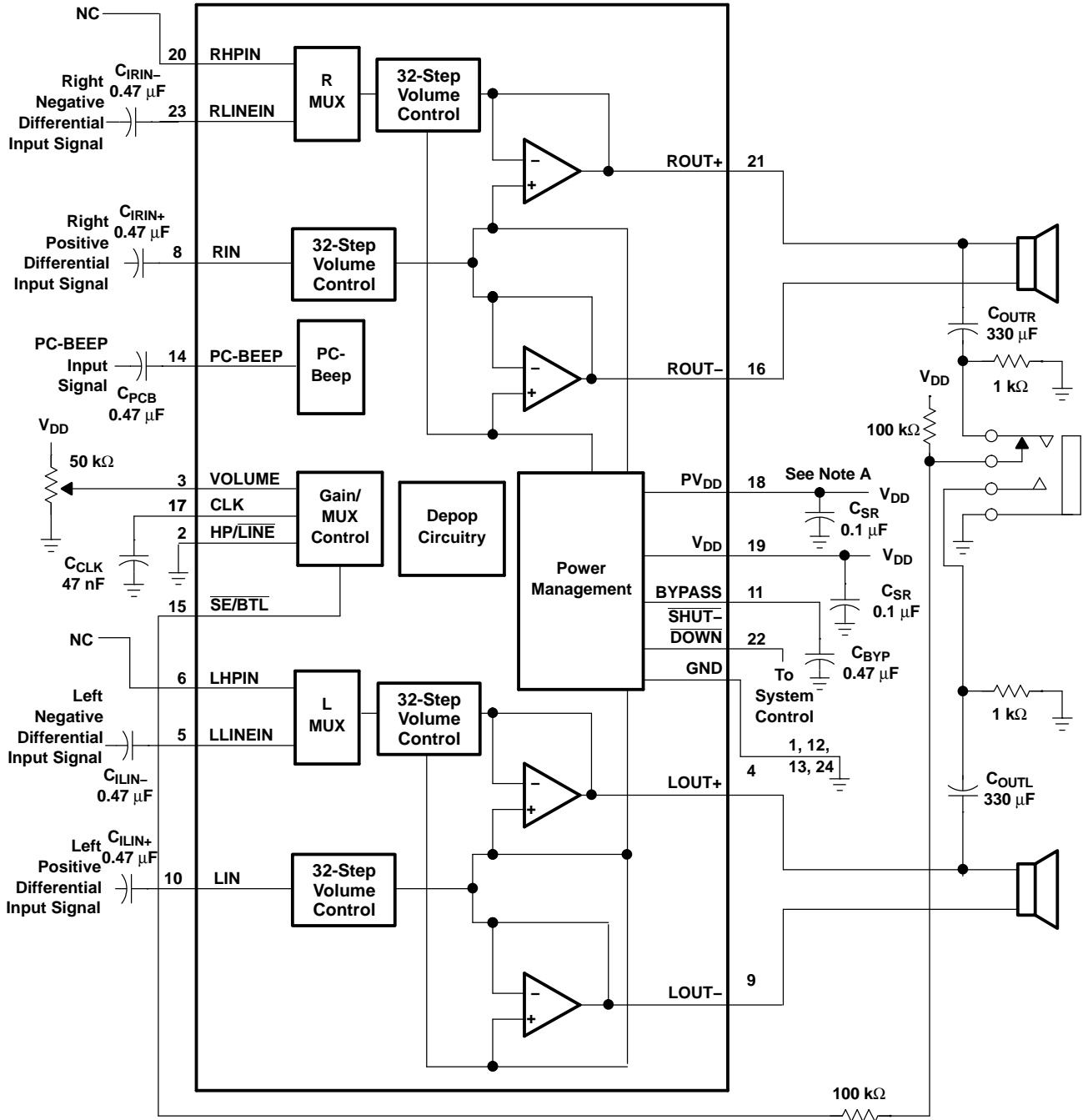

- A. A 0.1- μF ceramic capacitor should be placed as close as possible to the IC. For filtering lower-frequency noise signals, a larger electrolytic capacitor of 10 μF or greater should be placed near the audio power amplifier.

Figure 32. Typical TPA0242 Application Circuit Using Differential Inputs

APPLICATION INFORMATION (continued)

Volume Control Operation

The VOLUME pin controls the volume of the TPA0242. It is controlled with a dc voltage, which should not exceed V_{DD} . The gain voltages on the VOLUME pin are given in the Typical Characteristics section.

The trip point, where the gain actually changes, is different depending on whether the voltage on the VOLUME terminal is increasing or decreasing as a result of hysteresis about each trip point. The hysteresis ensures that the gain control is monotonic and does not oscillate from one gain step to another. A pictorial representation of the volume control can be found in Figure 33. The graph focuses on three gain steps with the trip points defined in the first and second columns of the Typical DC Volume Control table. The dotted lines represent the hysteresis about each gain step.

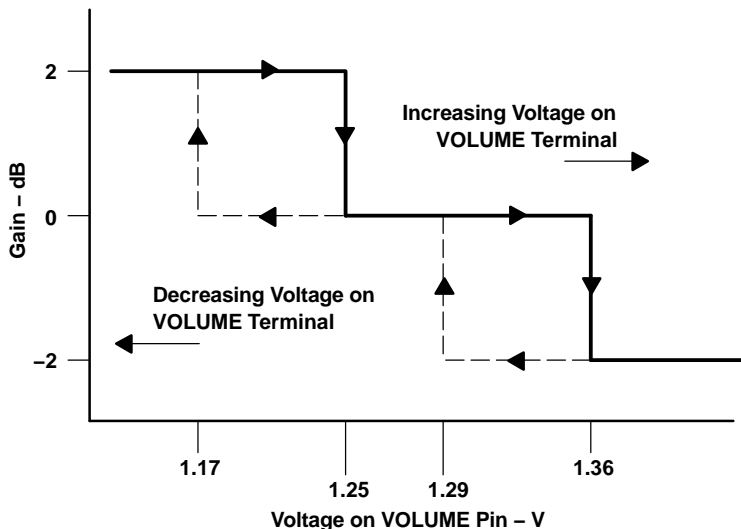

Figure 33. DC Volume Control Operation

INPUT RESISTANCE

The gain is set by varying the input resistance of the amplifier, which can range from its smallest value to over six times that value. As a result, if a single capacitor is used in the input high pass filter, the -3 dB or cut-off frequency also changes by over six times. Connecting an additional resistor from the input pin of the amplifier to ground, as shown in Figure 34, reduces the cutoff-frequency variation.

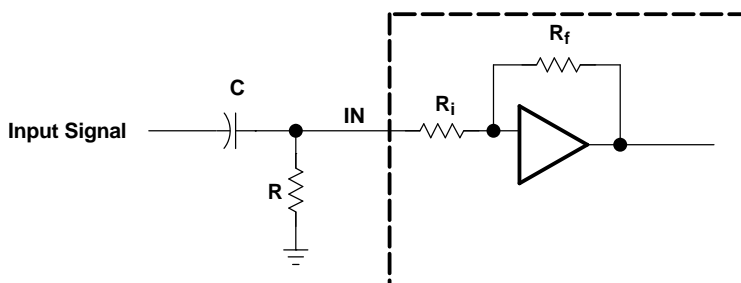

Figure 34. Resistor on Input for Cut-Off Frequency

The input resistance at each gain setting is given in the graph for Input Impedance vs Gain in the Typical Characteristics section.

The -3 -dB frequency can be calculated using Equation 1.

APPLICATION INFORMATION (continued)

$$f_{-3\text{ dB}} = \frac{1}{2\pi C(R \parallel R_i)} \quad (1)$$

To increase filter accuracy, increase the value of the capacitor and decrease the value of the resistor to ground. In addition, the order of the filter can be increased.

INPUT CAPACITOR, C_i

In a typical application, an input capacitor (C_i) is required to allow the amplifier to bias the input signal to the proper dc level for optimum operation. In this case, C_i and the input impedance of the amplifier (Z_i) form a high-pass filter with the corner frequency determined by Equation 2.

$$f_{c(\text{highpass})} = \frac{1}{2\pi Z_{\text{IN}} C_i}$$

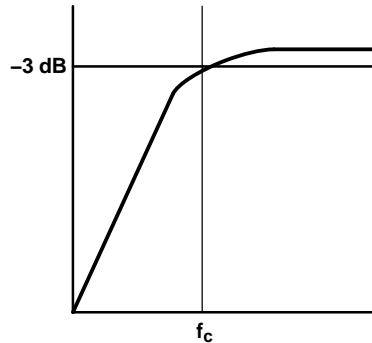

(2)

The value of C_i directly affects the bass (low frequency) performance of the circuit. Consider the example where Z_i is 55 k Ω and the specification calls for a flat bass response down to 30 Hz. Equation 2 is reconfigured as Equation 3.

$$C_i = \frac{1}{2\pi Z_i f_c} \quad (3)$$

In this example, C_i is 72 nF, so one would likely choose a value in the range of 0.1 μF to 1 μF . A further consideration for this capacitor is the leakage path from the input source through the input network (C_i) and the feedback network to the load. This leakage current creates a dc offset voltage at the input to the amplifier that reduces useful headroom, especially in high-gain applications. For this reason a low-leakage tantalum or ceramic capacitor is the best choice. When polarized capacitors are used, connect the positive lead of the capacitor to the amplifier input in most applications, as the dc level there is held at $V_{\text{DD}}/2$, typically higher than the source dc level. Note that it is important to confirm the capacitor polarity in the application.

POWER SUPPLY DECOUPLING, $C_{(S)}$

This high-performance CMOS audio amplifier requires adequate power-supply decoupling to minimize output total harmonic distortion (THD). Power-supply decoupling also prevents oscillations with long lead lengths between the amplifier and the speaker. Optimum decoupling is achieved by using two capacitors of different types that target different types of noise on the power-supply leads. To filter high-frequency transients, spikes, or digital hash on the line, a good low equivalent-series-resistance (ESR) ceramic capacitor, typically 0.1 μF , placed as close as possible to the device V_{DD} lead, works best. For filtering low-frequency noise signals, an aluminum electrolytic capacitor of 10 μF or greater placed near the audio power amplifier is recommended.

MIDRAIL BYPASS CAPACITOR, $C_{(\text{BYP})}$

The midrail bypass capacitor, $C_{(\text{BYP})}$, is the most critical capacitor and serves several important functions. During startup or recovery from shutdown mode, $C_{(\text{BYP})}$ determines the rate at which the amplifier starts up. The second function is to reduce power-supply noise coupling into the output drive signal. This noise is from the midrail generation circuit internal to the amplifier, and appears as degraded PSRR and THD+N.

Bypass capacitor ($C_{(\text{BYP})}$) values of 0.47- μF to 1- μF , and ceramic or tantalum low-ESR capacitors are recommended for best THD and noise performance.

APPLICATION INFORMATION (continued)**OUTPUT COUPLING CAPACITOR, $C_{(C)}$**

In a typical single-supply SE configuration, an output coupling capacitor ($C_{(C)}$) is required to block the dc bias at the output of the amplifier to prevent dc currents in the load. As with the input coupling capacitor, the output coupling capacitor and impedance of the load form a high-pass filter governed by Equation 4.

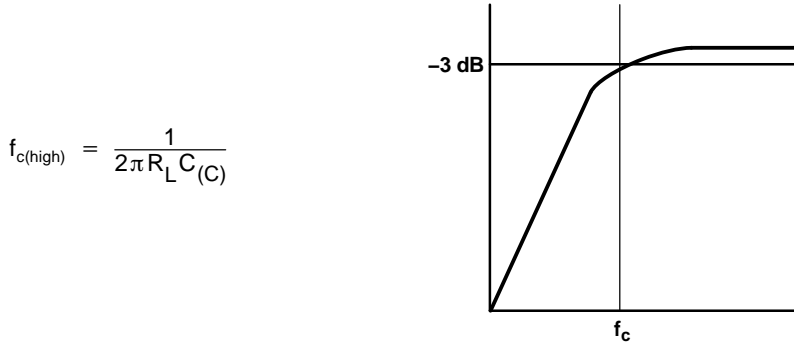

(4)

The main disadvantage, from a performance standpoint, is that load impedances are typically small, driving the low-frequency corner higher, degrading the bass response. Large values of $C_{(C)}$ are required to pass low frequencies into the load. Consider the example where a $C_{(C)}$ of 330 μF is chosen and loads include 3 Ω , 4 Ω , 8 Ω , 32 Ω , 10 k Ω , and 47 k Ω . Table 2 summarizes the frequency response characteristics of each configuration.

Table 2. Common Load Impedances Vs Low Frequency Output Characteristics in SE Mode

R_L	$C_{(C)}$	LOWEST FREQUENCY
3 Ω	330 μF	161 Hz
4 Ω	330 μF	120 Hz
8 Ω	330 μF	60 Hz
32 Ω	330 μF	15 Hz
10,000 Ω	330 μF	0.05 Hz
47,000 Ω	330 μF	0.01 Hz

As Table 2 indicates, most of the bass response is attenuated into a 4- Ω load, an 8- Ω load is adequate, headphone response is good, and drive into line level inputs (a home stereo for example) is exceptional.

USING LOW-ESR CAPACITORS

Low-ESR capacitors are recommended throughout this applications section. A real (as opposed to ideal) capacitor can be modeled simply as a resistor in series with an ideal capacitor. The voltage drop across this resistor minimizes the beneficial effects of the capacitor in the circuit. The lower the equivalent value of this resistance the more the real capacitor behaves like an ideal capacitor.

BRIDGED-TIED LOAD VS SINGLE-ENDED MODE

Figure 35 shows a Class-AB audio power amplifier (APA) in a BTL configuration. The TPA0242 amplifier consists of two Class-AB amplifiers driving both ends of the load. There are several potential benefits to this differential drive configuration, but, initially consider power to the load. The differential drive to the speaker means that as one side is slewing up, the other side is slewing down, and vice versa. This in effect doubles the voltage swing on the load as compared to a ground referenced load. Substituting $2 \times V_{O(PP)}$ into the power equation, where voltage is squared, yields $4\times$ the output power from the same supply rail and load impedance (see Equation 5).

$$V_{(rms)} = \frac{V_{O(PP)}}{2\sqrt{2}}$$

$$\text{Power} = \frac{V_{(rms)}^2}{R_L} \tag{5}$$

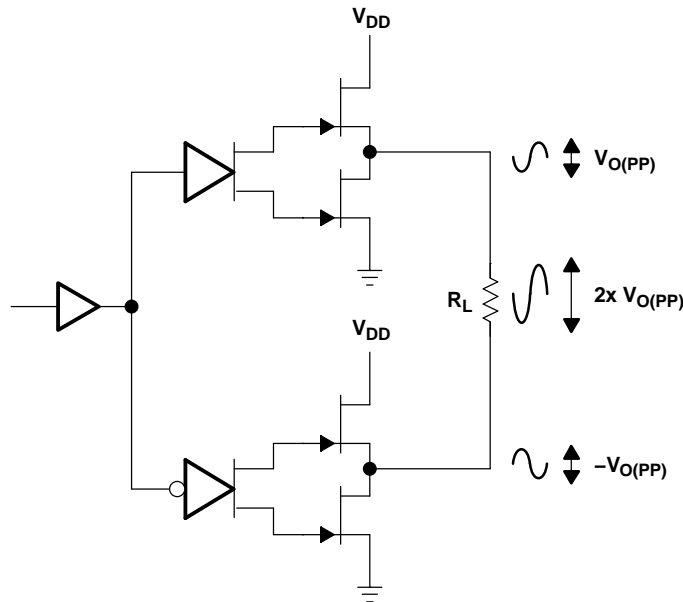

Figure 35. Bridge-Tied Load Configuration

In a typical computer sound channel operating at 5 V, bridging raises the power into an 8-Ω speaker from a singled-ended (SE, ground reference) limit of 250 mW to 1 W. In sound power, this is a 6-dB improvement — loudness that can be heard. In addition to increased power there are frequency-response concerns. Consider the single-supply SE configuration shown in Figure 36. A coupling capacitor is required to block the dc offset voltage from reaching the load. These capacitors can be quite large (approximately 33 μF to 1000 μF), so they tend to be expensive, heavy, occupy valuable PCB area, and have the additional drawback of limiting the low-frequency performance of the system. This frequency-limiting effect is due to the high-pass filter network created with the speaker impedance and the coupling capacitance, and is calculated with Equation 6.

$$f_{(c)} = \frac{1}{2\pi R_L C_{(C)}} \tag{6}$$

For example, a 68-μF capacitor with an 8-Ω speaker would attenuate low frequencies below 293 Hz. The BTL configuration cancels the dc offsets, eliminating the need for blocking capacitors. Low-frequency performance is then limited only by the input network and speaker response. Cost and PCB space are also minimized by eliminating the bulky coupling capacitor.

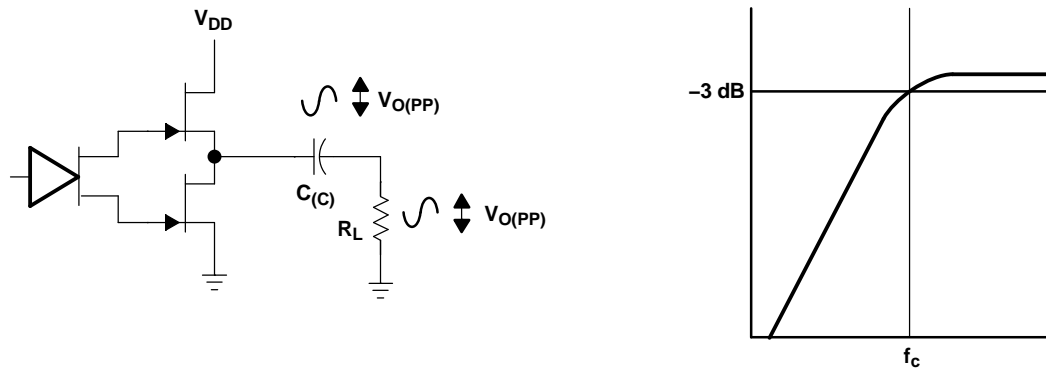

Figure 36. Single-Ended Configuration and Frequency Response

Increasing power to the load does carry a penalty of increased internal power dissipation. The increased dissipation is understandable, since the BTL configuration produces 4× the output power of the SE configuration. Internal dissipation versus output power is discussed further in the *Crest Factor and Thermal Considerations* section.

Single-Ended Operation

In SE mode (see Figure 36), the load is driven from the primary amplifier output for each channel (LOUT+ and ROUT+).

The amplifier switches to single-ended operation when the SE/BTL terminal is held high. This puts the negative outputs in a high-impedance state, and reduces the amplifier’s gain by 6 dB.

BTL AMPLIFIER EFFICIENCY

Class-AB amplifiers are inefficient, primarily because of voltage drop across the output-stage transistors. The two components of the internal voltage drop are the headroom or dc voltage drop that varies inversely to output power, and the sine wave nature of the output. The total voltage drop can be calculated by subtracting the RMS value of the output voltage from V_{DD} . The internal voltage drop multiplied by the RMS value of the supply current ($I_{DD,rms}$) determines the internal power dissipation of the amplifier.

An easy-to-use equation to calculate efficiency begins as the ratio of power from the power supply to the power delivered to the load. To accurately calculate the RMS and average values of power in the load and in the amplifier, the current and voltage waveforms must be understood (see Figure 37).

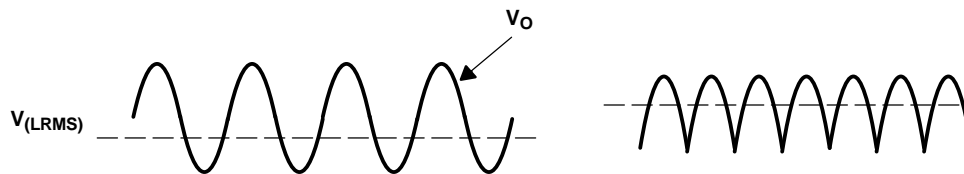

Figure 37. Voltage and Current Waveforms for BTL Amplifiers

Although the voltages and currents for SE and BTL are sinusoidal in the load, currents from the supply are very different between SE and BTL configurations. In an SE application, the current waveform is a half-wave rectified shape, whereas in BTL it is a full-wave rectified waveform. Therefore, RMS conversion factors are different. Keep in mind that for most of the waveform both the push and pull transistors are not on at the same time, which supports the fact that each amplifier in the BTL device only draws current from the supply for half the waveform. Equation 7 and Equation 8 are the basis for calculating amplifier efficiency.

$$\text{Efficiency of a BTL amplifier} = \frac{P_L}{P_{\text{SUP}}}$$

Where:

$$P_L = \frac{V_{L\text{rms}}^2}{R_L}, \text{ and } V_{L\text{RMS}} = \frac{V_P}{\sqrt{2}}, \text{ therefore, } P_L = \frac{V_P^2}{2R_L}$$

$$\text{and } P_{\text{SUP}} = V_{\text{DD}} I_{\text{DDavg}} \quad \text{and} \quad I_{\text{DDavg}} = \frac{1}{\pi} \int_0^{\pi} \frac{V_P}{R_L} \sin(t) dt = -\frac{1}{\pi} \times \frac{V_P}{R_L} [\cos(t)]_0^{\pi} = \frac{2V_P}{\pi R_L}$$

Therefore,

$$P_{\text{SUP}} = \frac{2 V_{\text{DD}} V_P}{\pi R_L}$$

substituting P_L and P_{SUP} into equation 7,

$$\text{Efficiency of a BTL amplifier} = \frac{\frac{V_P^2}{2R_L}}{\frac{2 V_{\text{DD}} V_P}{\pi R_L}} = \frac{\pi V_P}{4 V_{\text{DD}}}$$

Where:

$$V_P = \sqrt{2 P_L R_L} \tag{7}$$

Therefore,

$$\eta_{\text{BTL}} = \frac{\pi \sqrt{2 P_L R_L}}{4 V_{\text{DD}}}$$

P_L = Power delivered to load

P_{SUP} = Power drawn from power supply

$V_{L\text{RMS}}$ = RMS voltage on BTL load

R_L = Load resistance

V_P = Peak voltage on BTL load

I_{DDavg} = Average current drawn from the power supply

V_{DD} = Power supply voltage

η_{BTL} = Efficiency of a BTL amplifier

(8)

Table 3 employs Equation 8 to calculate efficiencies for four different output-power levels. Note that the efficiency of the amplifier is quite low for lower power levels and rises sharply as power to the load is increased resulting in a nearly flat internal power dissipation over the normal operating range. Note that the internal dissipation at full output power is less than in the half-power range. Calculating the efficiency for a specific system is the key to proper power supply design. For a stereo 1-W audio system with 8-Ω loads and a 5-V supply, the maximum draw on the power supply is almost 3.25 W.

Table 3. Efficiency vs Output Power in 5-V, 8-Ω BTL Systems

OUTPUT POWER (W)	EFFICIENCY (%)	PEAK VOLTAGE (V)	INTERNAL DISSIPATION (W)
0.25	31.4	2.00	0.55
0.50	44.4	2.83	0.62
1.00	62.8	4.00	0.59
1.25	70.2	4.47 ⁽¹⁾	0.53

(1) High peak voltages cause the THD to increase.

A final point to remember about Class-AB amplifiers (either SE or BTL) is how to manipulate the terms in the efficiency equation to utmost advantage when possible. Note that in Equation 8, V_{DD} is in the denominator. This indicates that as V_{DD} goes down, efficiency goes up.

Crest Factor and Thermal Considerations

Class-AB power amplifiers dissipate a significant amount of heat in the package under normal operating conditions. A typical music CD requires 12 dB to 15 dB of dynamic range, or headroom, above the average power output, to pass the loudest portions of the signal without distortion. In other words, music typically has a crest factor between 12 dB and 15 dB. When determining the optimal ambient operating temperature, the internal dissipated power at the average output power level must be used. From the data sheet, one can see that when the device is operating from a 5-V supply into a 3-Ω speaker that 4-W peaks are available. Use Equation 9 to convert watts to dB.

$$P_{dB} = 10 \text{Log} \frac{P_W}{P_{ref}} = 10 \text{Log} \frac{4 \text{ W}}{1 \text{ W}} = 6 \text{ dB} \quad (9)$$

Subtracting the headroom restriction to obtain the average listening level without distortion yields:

$$\begin{aligned} 6 \text{ dB} - 15 \text{ dB} &= -9 \text{ dB (15-dB crest factor)} \\ 6 \text{ dB} - 12 \text{ dB} &= -6 \text{ dB (12-dB crest factor)} \\ 6 \text{ dB} - 9 \text{ dB} &= -3 \text{ dB (9-dB crest factor)} \\ 6 \text{ dB} - 6 \text{ dB} &= 0 \text{ dB (6-dB crest factor)} \\ 6 \text{ dB} - 3 \text{ dB} &= 3 \text{ dB (3-dB crest factor)} \end{aligned}$$

Converting dB back into watts:

$$\begin{aligned} P_W &= 10^{P_{dB}/10} \times P_{ref} \\ &= 63 \text{ mW (18-dB crest factor)} \\ &= 125 \text{ mW (15-dB crest factor)} \\ &= 250 \text{ mW (9-dB crest factor)} \\ &= 500 \text{ mW (6-dB crest factor)} \\ &= 1000 \text{ mW (3-dB crest factor)} \\ &= 2000 \text{ mW (0-dB crest factor)} \end{aligned}$$

This is valuable information to consider when estimating the heat-dissipation requirements for the amplifier system. Comparing the worst case, 2 W of continuous power output with a 3-dB crest factor, against 12-dB and 15-dB applications, drastically affects maximum ambient temperature ratings for the system. Using the power dissipation curves for a 5-V, 3-Ω system, the internal dissipation and maximum ambient temperatures are shown in the table below.

Table 4. TPA0242 Power Rating, 5-V, 3-Ω Stereo

PEAK OUTPUT POWER (W)	AVERAGE OUTPUT POWER	POWER DISSIPATION (W/Channel)	MAXIMUM AMBIENT TEMPERATURE
4	2 W (3 dB)	1.7	-3°C
4	1000 mW (6 dB)	1.6	6°C
4	500 mW (9 dB)	1.4	24°C
4	250 mW (12 dB)	1.1	51°C
4	125 mW (15 dB)	0.8	78°C
4	63 mW (18 dB)	0.6	85°C ⁽¹⁾

(1) Package limited to 85°C ambient

Table 5. TPA0242 Power Rating, 5-V, 8-Ω Stereo

PEAK OUTPUT POWER (W)	AVERAGE OUTPUT POWER	POWER DISSIPATION (W/Channel)	MAXIMUM AMBIENT TEMPERATURE
2.5	1250 mW (3 dB crest factor)	0.55	85°C ⁽¹⁾
2.5	1000 mW (4 dB crest factor)	0.62	85°C ⁽¹⁾
2.5	500 mW (7 dB crest factor)	0.59	85°C ⁽¹⁾
2.5	250 mW (10 dB crest factor)	0.53	85°C ⁽¹⁾

(1) Package limited to 85°C ambient

The maximum dissipated power (P_{Dmax}) is reached at a much lower output power level for a 3-Ω load than for an 8-Ω load. As a result, the formula in Equation 10 for calculating P_{Dmax} may be used for a 3-Ω application:

$$P_{Dmax} = \frac{2V_{DD}^2}{\pi^2 R_L} \quad (10)$$

However, in the case of an 8-Ω load, the P_{Dmax} occurs at a point well above the normal operating power level. The amplifier may therefore be operated at a higher ambient temperature than required by the P_{Dmax} formula for an 8-Ω load, but do not exceed the maximum ambient temperature of 85°.

The maximum ambient temperature depends on the heatsinking ability of the PCB system. The derating factor for the PWP package is shown in the dissipation rating table. Converting this to θ_{JA} :

$$\theta_{JA} = \frac{1}{\text{Derating Factor}} = \frac{1}{0.022} = 45^\circ\text{C/W} \quad (11)$$

To calculate maximum ambient temperatures, first consider that the numbers from the dissipation graphs are per-channel, so the dissipated heat is doubled for two-channel operation. Given θ_{JA} , the maximum allowable junction temperature, and the total internal dissipation, the maximum ambient temperature can be calculated using Equation 12. The maximum recommended junction temperature for the device is 150°C. The internal dissipation figures are taken from the Power Dissipation vs Output Power graphs.

$$\begin{aligned} T_{A \text{ Max}} &= T_{J \text{ Max}} - \theta_{JA} P_D \\ &= 150 - 45(0.6 \times 2) = 96^\circ\text{C (15-dB crest factor)} \end{aligned} \quad (12)$$

NOTE:

Internal dissipation of 0.6 W is estimated for a 2-W system with 15-dB crest factor per channel.

Due to package limitations, the actual T_{AMAX} is 85°C.

The power rating tables show that for some applications, no airflow is required to keep junction temperatures in the specified range. The internal thermal protection turns the device off at junction temperatures higher than 150°C to prevent damage to the IC. The power rating tables in this section were calculated for maximum listening volume without distortion. When the output level is reduced the numbers in the table change significantly. Also, using 8-Ω speakers dramatically increases the thermal performance by increasing amplifier efficiency.

SE/BTL OPERATION

The ability of the TPA0242 to easily switch between BTL and SE modes is one of its most important cost-saving features. This feature eliminates the requirement for an additional headphone amplifier in applications where internal stereo speakers are driven in BTL mode but external headphone or speakers must be accommodated. Two separate internal amplifiers drive $OUT+$ and $OUT-$. The SE/BTL input controls the operation of the follower amplifier that drives $LOUT-$ and $ROUT-$. When SE/BTL is held low, the amplifier is on and the device is in the BTL mode. When SE/BTL is held high, the $OUT-$ amplifiers are in a high output-impedance state, which configures the device outputs as SE drivers from $LOUT+$ and $ROUT+$. I_{DD} is reduced by approximately one-half in SE mode. Control of the SE/BTL input can be from a logic-level CMOS source or, more typically, from a resistor-divider network as shown in Figure 38.

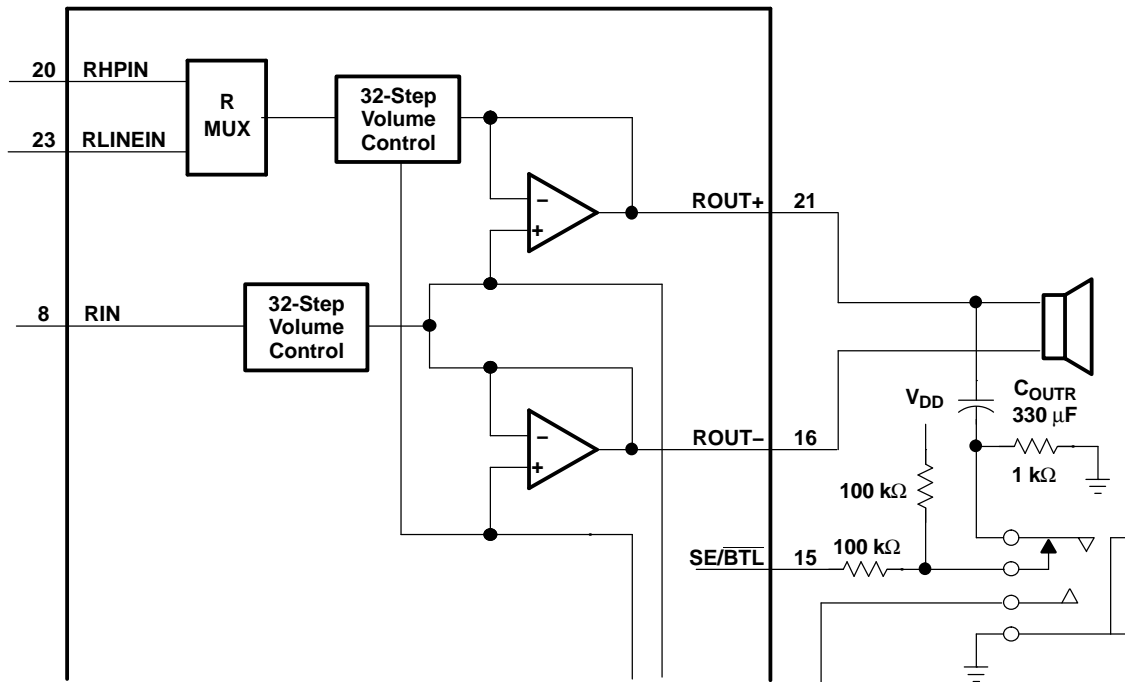

Figure 38. TPA0242 Resistor Divider Network Circuit

Using a readily-available 1/8-in. (3,5 mm) stereo headphone jack, the control switch is closed when no plug is inserted. When closed, the 100-kΩ/1-kΩ divider pulls the SE/BTL input low. When a plug is inserted, the 1-kΩ resistor is disconnected and the SE/BTL input is pulled high. When the input goes high, the $OUT-$ amplifier is shut down, muting the speaker (virtually open-circuits the speaker). The $OUT+$ amplifier then drives through the output capacitor (C_O) into the headphone jack.

PC-BEEP OPERATION

The PC-BEEP input allows a system beep to be sent directly from a computer through the amplifier to the speakers with few external components. The input is activated automatically. When the PC-BEEP input is active, both LINEIN and HPIN inputs are deselected, and both the left and right channels are driven in BTL mode with the signal from PC-BEEP. The gain from the PC-BEEP input to the speakers is fixed at 0.3 V/V and is independent of the volume setting. When the PC-BEEP input is deselected, the amplifier returns to the previous operating mode and volume setting. Furthermore, if the amplifier is in shutdown mode, activating PC-BEEP takes the device out of shutdown, outputs the PC-BEEP signal, then returns the amplifier to shutdown mode.

The preferred input signal is a square wave or pulse train. To be accurately detected, the signal must have a minimum of $1.5 \cdot V_{pp}$ amplitude, rise and fall times of less than $0.1 \mu s$ and a minimum of eight rising edges. When the signal is no longer detected, the amplifier returns to its previous operating mode and volume setting.

To ac-couple the PC-BEEP input, choose a coupling-capacitor value to satisfy Equation 13.

$$C_{PCB} \geq \frac{1}{2\pi f_{PCB} (100 \text{ k}\Omega)} \quad (13)$$

The PC-BEEP input can also be dc-coupled to avoid using this coupling capacitor. The pin normally rests at midrail when no signal is present.

Shutdown Modes

The TPA0242 employs a shutdown mode of operation designed to minimize supply current (I_{DD}) during periods of nonuse to conserve battery power. The $\overline{\text{SHUTDOWN}}$ input terminal should be held high during normal operation when the amplifier is in use. Pulling $\overline{\text{SHUTDOWN}}$ low mutes the outputs and puts the amplifier in a low-current state, with $I_{DD} = 150 \mu A$. $\overline{\text{SHUTDOWN}}$ should never be left unconnected because amplifier operation would be unpredictable.

Table 6. HP/LINE, SE/BTL, and Shutdown Functions

INPUTS ⁽¹⁾			AMPLIFIER STATE	
HP/LINE	SE/BTL	SHUTDOWN	INPUT	OUTPUT
X	X	Low	X	Mute
Low	Low	High	Line	BTL
Low	High	High	Line	SE
High	Low	High	HP	BTL
High	High	High	HP	SE

(1) Do not leave inputs unconnected.

INPUT MUX OPERATION

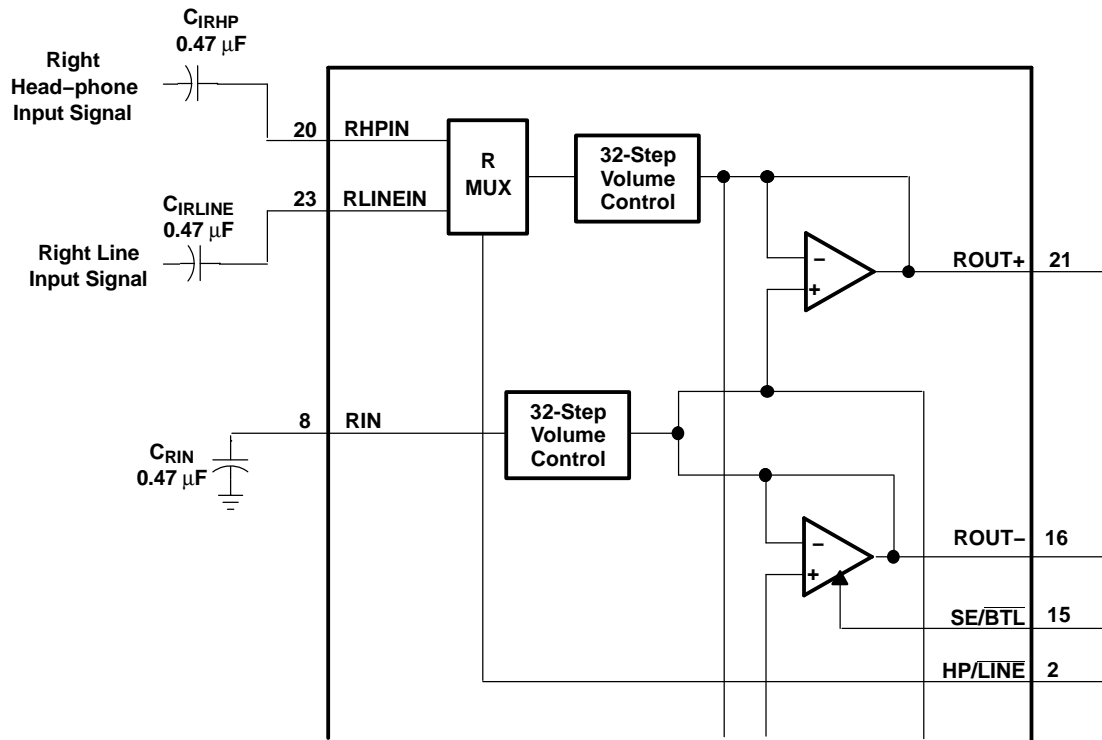

Figure 39. TPA0242 Example Input MUX Circuit

The TPA0242 offers the capability for the designer to use separate headphone inputs (RHPIN, LHPIN) and line inputs (RLINEIN, LLINEIN). The inputs can be different if the input signal is single-ended. If using a differential input signal, the inputs must be the same because the inputs share a common RIN, LIN. Although the typical application in Figure 31 shows the input mux control signal HP/LINE tied to SE/BTL, that configuration is not required. The input mux can be used to select between two inputs that are used in both SE and BTL modes.

If using the TPA0242 with a single-ended input, the RIN and LIN terminals must be tied through a capacitor to ground, as shown in Figure 39. RIN and LIN must not be tied to bypass or an offset occurs on the output causing the device to pop when turning on and off.

Input coupling capacitors can be eliminated when using differential inputs, but are used to obtain maximum output power. If the input capacitors are eliminated, the dc offset must match the voltage on BYPASS or the output power is limited.

PACKAGING INFORMATION

Orderable Device	Status ⁽¹⁾	Package Type	Package Drawing	Pins	Package Qty	Eco Plan ⁽²⁾	Lead/Ball Finish	MSL Peak Temp ⁽³⁾
TPA0242PWP	ACTIVE	HTSSOP	PWP	24	60	None	CU NIPDAU	Level-1-220C-UNLIM
TPA0242PWPR	ACTIVE	HTSSOP	PWP	24	2000	None	CU NIPDAU	Level-1-220C-UNLIM
TPA0242PWPRG4	ACTIVE	HTSSOP	PWP	24	2000	Green (RoHS & no Sb/Br)	CU NIPDAU	Level-2-260C-1 YEAR

⁽¹⁾ The marketing status values are defined as follows:

ACTIVE: Product device recommended for new designs.

LIFEBUY: TI has announced that the device will be discontinued, and a lifetime-buy period is in effect.

NRND: Not recommended for new designs. Device is in production to support existing customers, but TI does not recommend using this part in a new design.

PREVIEW: Device has been announced but is not in production. Samples may or may not be available.

OBSOLETE: TI has discontinued the production of the device.

⁽²⁾ Eco Plan - May not be currently available - please check <http://www.ti.com/productcontent> for the latest availability information and additional product content details.

None: Not yet available Lead (Pb-Free).

Pb-Free (RoHS): TI's terms "Lead-Free" or "Pb-Free" mean semiconductor products that are compatible with the current RoHS requirements for all 6 substances, including the requirement that lead not exceed 0.1% by weight in homogeneous materials. Where designed to be soldered at high temperatures, TI Pb-Free products are suitable for use in specified lead-free processes.

Green (RoHS & no Sb/Br): TI defines "Green" to mean "Pb-Free" and in addition, uses package materials that do not contain halogens, including bromine (Br) or antimony (Sb) above 0.1% of total product weight.

⁽³⁾ MSL, Peak Temp. -- The Moisture Sensitivity Level rating according to the JEDEC industry standard classifications, and peak solder temperature.

Important Information and Disclaimer: The information provided on this page represents TI's knowledge and belief as of the date that it is provided. TI bases its knowledge and belief on information provided by third parties, and makes no representation or warranty as to the accuracy of such information. Efforts are underway to better integrate information from third parties. TI has taken and continues to take reasonable steps to provide representative and accurate information but may not have conducted destructive testing or chemical analysis on incoming materials and chemicals. TI and TI suppliers consider certain information to be proprietary, and thus CAS numbers and other limited information may not be available for release.

In no event shall TI's liability arising out of such information exceed the total purchase price of the TI part(s) at issue in this document sold by TI to Customer on an annual basis.

PWP (R-PDSO-G**)

PowerPAD™ PLASTIC SMALL-OUTLINE PACKAGE

20 PIN SHOWN

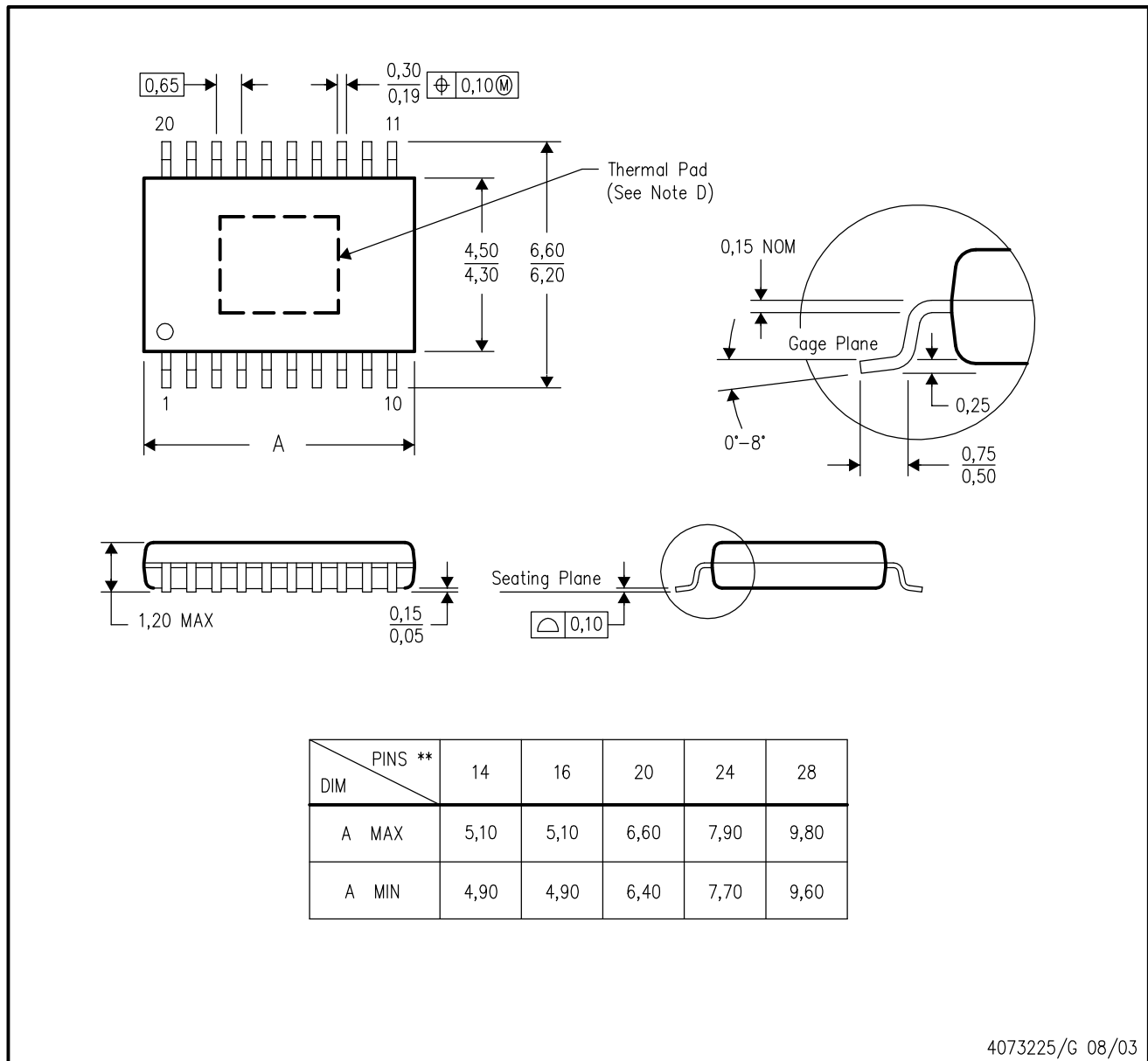

- NOTES:
- A. All linear dimensions are in millimeters.
 - B. This drawing is subject to change without notice.
 - C. Body dimensions do not include mold flash or protrusions.
 - D. This package is designed to be soldered to a thermal pad on the board. Refer to Technical Brief, PowerPad Thermally Enhanced Package, Texas Instruments Literature No. SLMA002 for information regarding recommended board layout. This document is available at www.ti.com <<http://www.ti.com>>.
 - E. Falls within JEDEC MO-153

PowerPAD is a trademark of Texas Instruments.

IMPORTANT NOTICE

Texas Instruments Incorporated and its subsidiaries (TI) reserve the right to make corrections, modifications, enhancements, improvements, and other changes to its products and services at any time and to discontinue any product or service without notice. Customers should obtain the latest relevant information before placing orders and should verify that such information is current and complete. All products are sold subject to TI's terms and conditions of sale supplied at the time of order acknowledgment.

TI warrants performance of its hardware products to the specifications applicable at the time of sale in accordance with TI's standard warranty. Testing and other quality control techniques are used to the extent TI deems necessary to support this warranty. Except where mandated by government requirements, testing of all parameters of each product is not necessarily performed.

TI assumes no liability for applications assistance or customer product design. Customers are responsible for their products and applications using TI components. To minimize the risks associated with customer products and applications, customers should provide adequate design and operating safeguards.

TI does not warrant or represent that any license, either express or implied, is granted under any TI patent right, copyright, mask work right, or other TI intellectual property right relating to any combination, machine, or process in which TI products or services are used. Information published by TI regarding third-party products or services does not constitute a license from TI to use such products or services or a warranty or endorsement thereof. Use of such information may require a license from a third party under the patents or other intellectual property of the third party, or a license from TI under the patents or other intellectual property of TI.

Reproduction of information in TI data books or data sheets is permissible only if reproduction is without alteration and is accompanied by all associated warranties, conditions, limitations, and notices. Reproduction of this information with alteration is an unfair and deceptive business practice. TI is not responsible or liable for such altered documentation.

Resale of TI products or services with statements different from or beyond the parameters stated by TI for that product or service voids all express and any implied warranties for the associated TI product or service and is an unfair and deceptive business practice. TI is not responsible or liable for any such statements.

Following are URLs where you can obtain information on other Texas Instruments products and application solutions:

Products		Applications	
Amplifiers	amplifier.ti.com	Audio	www.ti.com/audio
Data Converters	dataconverter.ti.com	Automotive	www.ti.com/automotive
DSP	dsp.ti.com	Broadband	www.ti.com/broadband
Interface	interface.ti.com	Digital Control	www.ti.com/digitalcontrol
Logic	logic.ti.com	Military	www.ti.com/military
Power Mgmt	power.ti.com	Optical Networking	www.ti.com/opticalnetwork
Microcontrollers	microcontroller.ti.com	Security	www.ti.com/security
		Telephony	www.ti.com/telephony
		Video & Imaging	www.ti.com/video
		Wireless	www.ti.com/wireless

Mailing Address: Texas Instruments
Post Office Box 655303 Dallas, Texas 75265